



HEIDENHAIN



HEIDENHAIN Motors

For Axis and Spindle Drives

Information for
Machine Manufacturers

Table of contents

Motors for feed axes and main spindles

HEIDENHAIN supplies motors for feed axes and main spindles as accessories to its controls with an integrated inverter. This brochure provides an overview of the available motors as well as information about the specifications and mating dimensions. For initial setup, please request the *Motors Technical Manual*.

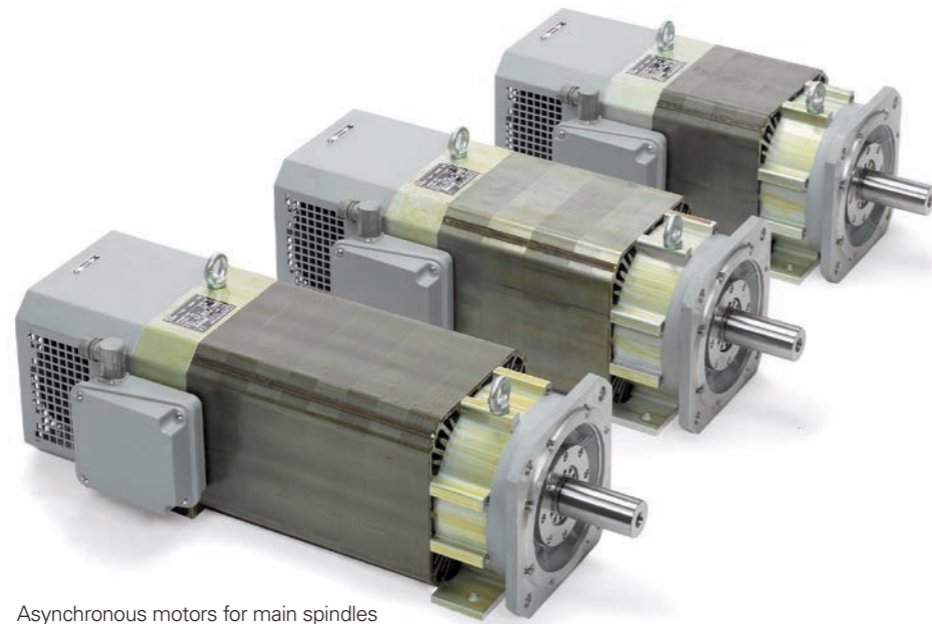

Asynchronous motors for main spindles



Synchronous motors for feed drives

Intended use

- The products described in this brochure:
- May be used only for NC-controlled machine tools
 - Should be operated only with controls and inverters from HEIDENHAIN (operation with non-HEIDENHAIN controls or inverters requires prior consultation with HEIDENHAIN).
 - May be used only in an industrial setting, for commercial applications or in research institutions
 - May be operated only in accordance with the product requirements (specifications, environmental data, safety instructions, etc.)

If the devices are used as a part of a safety function, then the machine manufacturer must ensure that the final product fulfills all requirements of the Machinery Directive (2006/42/EC).

Improper use

The devices are not intended for applications in areas where a failure would result in considerable risk to humans or the environment. Usage in potentially explosive atmospheres is prohibited.

Parts subject to wear

HEIDENHAIN motors contain components that are subject to wear depending on the application and how they are deployed. This especially applies to the following parts:

- Bearings
- Brakes
- Radial shaft seal rings
- Fans
- Electrical insulation system

This brochure supersedes all previous editions, which thereby become invalid. The basis for ordering from HEIDENHAIN is always the brochure edition valid when the order is placed.

Standards (ISO, EN, etc.) apply only where explicitly stated in this brochure.

Synchronous motors	QSY overview		4
	Specifications	Series QSY 96	8
		Series QSY 116 QSY 116 EcoDyn	10
		Series QSY 130 EcoDyn	12
		Series QSY 155	14
		Series QSY 155 EcoDyn	16
		Series QSY 190 EcoDyn	18
		Series QSY 260 EcoDyn	20
	MSY overview		22
	Specifications	Series MSY 155	24
Series MSY 192		26	
Torque characteristic curves		28	
Cables and connectors		32	
Asynchronous motors	QAN overview		34
	Specifications	Series QAN 200	38
		Series QAN 260	40
		Series QAN 320	42
		QAN 200UH	44
		Series QAN 260xH	46
		Series QAN 360UHW	48
	QAN power and torque characteristics		50
	Cables		56
	Accessories	Toroidal cores M23 connector set	58
Direct-drive torque motors		59	

Synchronous motors

QSY overview

General technical information

Synchronous motors from HEIDENHAIN fulfill all requirements of an NC-controlled machine tool. Some special characteristics include

- excellent running smoothness,
- an appropriate mass moment of inertia,
- a very good ratio of the rated torque to the stall torque,
- and low torque ripple.

Specifications

The specifications and characteristic curves apply to motors mounted without thermal insulation. The temperature of the winding may differ from the maximum permissible ambient temperature of 40 °C by a maximum of 100 K. If the motor is mounted so that it is thermally insulated, the motor torque must be reduced in order to avoid thermal overloading. For motors with EQN 1325 absolute rotary encoders, the rated torque is reduced by 10%.



QSY 116 E

Speed measurement

Synchronous motors from HEIDENHAIN operate with sinusoidal commutation. An integrated rotary encoder from HEIDENHAIN measures the rotor position and monitors the speed. The following versions are available (see *Specifications*):

- ERN 1387 incremental rotary encoder with $\sim 1 V_{PP}$ interface, or
- EQN 1325 absolute multiturn rotary encoder with EnDat2.2/01 interface or
- EQN 1337 absolute rotary encoder with purely serial EnDat2.2 interface

Mechanical service life

The service life of the bearings depends on the shaft load and the average shaft speed (see the *Motors Technical Manual*). For QSY motors, the nominal bearing service life—which depends on the specific motor and applies for a certain maximum shaft load at an average shaft speed—is 30 000 hours.



QSY 155 B

EcoDyn motors

Motors of the EcoDyn series are characterized by reduced current consumption together with a higher rated torque and a maximum permissible rated speed of 3000 rpm (QSY 260: 2000 rpm). The following controls are required in order to drive the motors in EcoDyn mode:

- TNC7, TNC7 basic
- TNC 640
- TNC 620
- MANUALplus 620
- CNC PILOT 640

For all other controls, the rated speed is 2000 rpm.

Electronic ID label

The synchronous motors with EQN 1325 rotary encoder feature an electronic ID label that allows for easy commissioning and diagnosis. The information, such as motor designation, ID number or serial number, stored in this ID label can be read and displayed by the internal diagnostic function DriveDiag of HSCI controls. Thus, the control automatically recognizes the motor type every time it is switched on.

Functional safety

All current QSY motor variants described in this brochure provide a fault exclusion for the loosening of the mechanical connection between the encoder and the motor. This prevents any unintended loosening of the rotor and stator coupling. Safety-related parameters for the motors or the encoders used within them are available upon request (e.g., MTTF values, data for fault exclusion).

Installation elevation

HEIDENHAIN motors may be installed at an elevation of up to 1000 m above sea level. For installation at elevations above 1000 m, additional cooling measures are required.

Thermal parameters

Natural cooling
Temperature monitoring with KTY 84-130 thermistor in the stator winding
Thermal class F

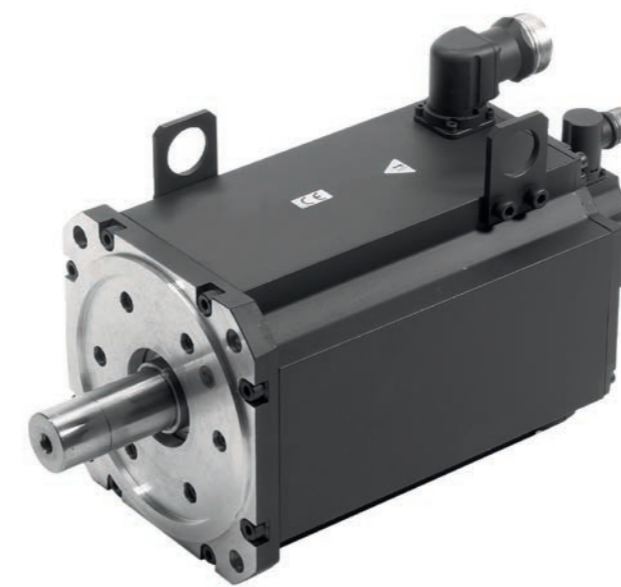

QSY 190 EcoDyn

Mechanical parameters

Maintenance-free bearings
Holding brake optionally with low backlash $\leq 1^\circ$
Design: IM B5 (mounting via flange)
as per EN 60034-7

Mounting the motor

The following screws are recommended for mounting the motor:

QSY 96	M6
QSY 116	M8
QSY 130	M8
QSY 155	M10
QSY 190	M12
QSY 260	M16

Flange: dimensions as per DIN EN 50347 and IEC 60072-1

Protection as per DIN EN 60529

- Motor: IP65
- Shaft exit: IP64

Suitability with regard to gears

Only for enclosed gears. The shaft is suitable only for dry connection.



QSY 96 G

Vibration severity

Grade A as per IEC 60034-14

Radial runout, concentricity and axial runout

Tolerance N as per IEC 60072-1 (DIN 42955)

Shaft end

Cylindrical without keyway as per IEC 60072-1 with center hole and thread
Shaft with keyway and machine key as per DIN 6885 (upon request)

- QSY 96: A 6 x 6 x 32
- QSY 116: A 8 x 7 x 40
- QSY 130: A 8 x 7 x 40
- QSY 155: A 10 x 8 x 50
- QSY 190: A 10 x 8 x 70
- QSY 260: A 14 x 9 x 70

The motors with machine key are half-key balanced as per ISO 21940-32.

Synchronous motors When used with 1xx inverter systems

Synchronous motors	Stall torque	Stall current	Rated speed	Recommended inverters ²⁾				Page
				1-axis module	2-axis module	Compact inverters/axis UR 2xx D UE 2xx B		
QSY 96A	1.5 Nm	1.5 A	4500 rpm	UM 111 D	UM 121 D	1 to 4	1 to 4	8
QSY 96G	5.2 Nm	5.2 A	4500 rpm	UM 111 D	UM 121 D	1 to 4	1 to 4	
QSY 116C	5.2 Nm	3.3 A	3000 rpm	UM 111 D	UM 121 D	1 to 4	1 to 4	10
QSY 116E	7.2 Nm	4.8 A	3000 rpm	UM 111 D	UM 121 D	1 to 4	4	
QSY 116J	10.0 Nm	6.8 A	3000 rpm	UM 111 D	UM 121 D	1 to 4	4	
QSY 116J EcoDyn	10.0 Nm	5.0 A	3000 rpm	UM 111 D	UM 121 D	1 to 4	4	
QSY 130C EcoDyn	6.0 Nm	3.0 A	3000 rpm	UM 111 D	UM 121 D	1 to 4	1 to 4	12
QSY 130E EcoDyn	9.0 Nm	4.5 A	3000 rpm	UM 111 D	UM 121 D	1 to 4	1 to 4	
QSY 155B	13.0 Nm	9.1 A	3000 rpm	UM 111 BD	UM 121 BD	4	–	14
QSY 155C	17.7 Nm	11.8 A	3000 rpm	UM 111 BD	UM 121 BD	4	–	
QSY 155D	21.6 Nm	14.6 A	3000 rpm	UM 111 BD	UM 121 BD	4	–	
QSY 155F	26.1 Nm	18.0 A	3000 rpm	UM 112 D	UM 122 D	4 ¹⁾	–	
QSY 155B EcoDyn	13.0 Nm	6.5 A	3000 rpm	UM 111 D	UM 121 D	1 to 4	–	16
QSY 155C EcoDyn	17.7 Nm	8.5 A	3000 rpm	UM 111 BD	UM 121 BD	4	–	
QSY 155D EcoDyn	21.6 Nm	10.6 A	3000 rpm	UM 111 BD	UM 121 BD	4	–	
QSY 155F EcoDyn	26.1 Nm	12.8 A	3000 rpm	UM 111 BD	UM 121 BD	4	–	
QSY 190C EcoDyn	28.0 Nm	14.0 A	3000 rpm	UM 111 BD	UM 121 BD	4	–	18
QSY 190D EcoDyn	38.0 Nm	18.1 A	3000 rpm	UM 112 D	UM 122 D	4 ¹⁾	–	
QSY 190F EcoDyn	47.6 Nm	22.7 A	3000 rpm	UM 112 D	UM 122 D	4 ¹⁾	–	
QSY 190K EcoDyn	62.5 Nm	29.8 A	3000 rpm	UM 113 D	–	–	–	
QSY 260B EcoDyn	85.0 Nm	31.0 A	2000 rpm	UM 114 D	–	–	–	20
QSY 260C EcoDyn	120 Nm	43.5 A	2000 rpm	UM 115 D	–	–	–	

¹⁾ Only UE 242 B, UR 242 D

²⁾ The maximum acceleration of the motor might not be achievable with the recommended inverters.
If necessary, a more powerful power module must be selected.

When used with Gen 3 drives

Synchronous motors	Stall torque	Stall current	Rated speed	Recommended inverters ¹⁾					Page
				1-axis module	2-axis module	Compact inverters/axis UEC 31x UEC 32x UEC 33x			
QSY 96A	1.5 Nm	1.5 A	4500 rpm	UM 310	UM 320	1 to 5	1 to 5	1 to 5	8
QSY 96G	5.2 Nm	5.2 A	4500 rpm	UM 310	UM 320	1 to 5	1 to 5	1 to 5	
QSY 116C	5.2 Nm	3.3 A	3000 rpm	UM 310	UM 320	1 to 5	1 to 5	1 to 5	10
QSY 116E	7.2 Nm	4.8 A	3000 rpm	UM 310	UM 320	1 to 5	1 to 5	1 to 5	
QSY 116J	10.0 Nm	6.8 A	3000 rpm	UM 310	UM 320	1 to 5	1 to 5	1 to 5	
QSY 116J EcoDyn	10.0 Nm	5.0 A	3000 rpm	UM 310	UM 320	1 to 5	1 to 5	1 to 5	
QSY 130C EcoDyn	6.0 Nm	3.0 A	3000 rpm	UM 310	UM 320	1 to 5	1 to 5	1 to 5	12
QSY 130E EcoDyn	9.0 Nm	4.5 A	3000 rpm	UM 310	UM 320	1 to 5	1 to 5	1 to 5	
QSY 155B	13.0 Nm	9.1 A	3000 rpm	UM 310	UM 320	1 to 2	1 to 5	1 to 5	14
QSY 155C	17.7 Nm	11.8 A	3000 rpm	UM 311	UM 321	1 to 2	1 to 2	1 to 5	
QSY 155D	21.6 Nm	14.6 A	3000 rpm	UM 311	UM 321	1 to 2	1 to 2	1 to 5	
QSY 155F	26.1 Nm	18.0 A	3000 rpm	UM 312	UM 322	–	1 to 2	1 to 2	
QSY 155B EcoDyn	13.0 Nm	6.5 A	3000 rpm	UM 310	UM 320	1 to 5	1 to 5	1 to 5	16
QSY 155C EcoDyn	17.7 Nm	8.5 A	3000 rpm	UM 310	UM 320	1 to 2	1 to 5	1 to 5	
QSY 155D EcoDyn	21.6 Nm	10.6 A	3000 rpm	UM 311	UM 321	1 to 2	1 to 2	1 to 5	
QSY 155F EcoDyn	26.1 Nm	12.8 A	3000 rpm	UM 311	UM 321	1 to 2	1 to 2	1 to 5	
QSY 190C EcoDyn	28.0 Nm	14.0 A	3000 rpm	UM 311	UM 321	1 to 2	1 to 2	1 to 5	18
QSY 190D EcoDyn	38.0 Nm	18.1 A	3000 rpm	UM 312	UM 322	–	1 to 2	1 to 2	
QSY 190F EcoDyn	47.6 Nm	22.7 A	3000 rpm	UM 312	UM 322	–	–	1 to 2	
QSY 190K EcoDyn	62.5 Nm	29.8 A	3000 rpm	UM 313	–	–	–	1	
QSY 260B EcoDyn	85.0 Nm	31.0 A	2000 rpm	UM 313	–	–	–	1	20
QSY 260C EcoDyn	120.0 Nm	43.5 A	2000 rpm	UM 313	–	–	–	–	
MSY 155B	12.8 Nm	7.8 A	2500 rpm	UM 310	UM 320	1 to 5	1 to 5	1 to 5	24
MSY 155C	18.2 Nm	10.5 A	2500 rpm	UM 311	UM 321	1 to 2	1 to 5	1 to 5	
MSY 155D	24.1 Nm	13.5 A	2500 rpm	UM 311	UM 321	1 to 2	1 to 2	1 to 5	
MSY 155E	28.9 Nm	15.5 A	2500 rpm	UM 311	UM 321	1 to 2	1 to 2	1 to 5	
MSY 192C	30.3 Nm	13.2 A	2000 rpm	UM 311	UM 321	1 to 2	1 to 2	1 to 2	26
MSY 192D	39.0 Nm	18.3 A	2000 rpm	UM 312	UM 322	–	1 to 2	1 to 2	
MSY 192E	46.0 Nm	20.1 A	2000 rpm	UM 312	UM 322	–	1 to 2	1 to 2	
MSY 192F	54.5 Nm	24.0 A	2000 rpm	UM 312	UM 322	–	–	1 to 2	

¹⁾ The maximum acceleration of the motor might not be achievable with the recommended inverters.
If necessary, a more powerful power module must be selected.

Synchronous motors

QSY 96 series

Feed motors with three pole pairs

- Stall torque: 1.5 Nm and 5.2 Nm
- Choice of incremental or absolute rotary encoder

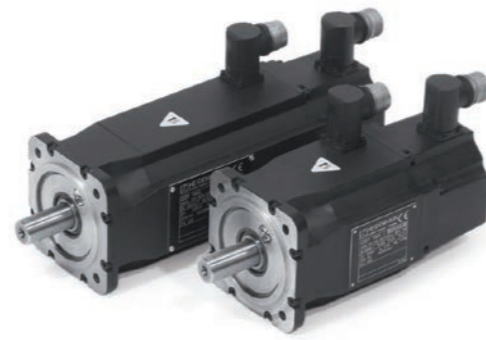

Motor	QSY 96A		QSY 96G	
Rated voltage U_N	310 V/308 V		291 V/290 V	
Rated power output P_N	0.5 kW/0.45 kW		1.4 kW/1.3 kW	
Rated shaft speed n_N	4500 rpm			
Rated torque $M_N^{1)}$	1.05 Nm/0.95 Nm		3.0 Nm/2.7 Nm at 4500 rpm	
Rated current $I_N^{1)}$	1.1 A/1.0 A		3.3 A/3.0 A	
Stall torque $M_0^{1)}$	1.5 Nm		5.2 Nm	
Stall current $I_0^{1)}$	1.5 A		5.2 A	
Maximum speed n_{max}	6000 rpm			
Max. torque $M_{max}^{2)}$	5.5 Nm		22 Nm	
Max. current $I_{max}^{2)}$	6.3 A		25.4 A	
Brake	Without	With	Without	With
Rated voltage U_{Br}	–	DC 24 V	–	DC 24 V
Rated current I_{Br}	–	0.5 A	–	0.5 A
Holding torque M_{Br}	–	5.0 Nm	–	5.0 Nm
Mass m	3.6 kg	4.5 kg	7.2 kg	8.1 kg
Rotor inertia J	1.8 kg·cm ²	2.1 kg·cm ²	6.3 kg·cm ²	6.6 kg·cm ²
ID				
Motor with ERN 1387	344512-0C	344512-0D	339875-0C	339875-0D
Motor with EQN 1325	344512-5C	344512-5D	339875-5C	339875-5D
Motor with EQN 1337	344512-4C	344512-4D	339875-4C	339875-4D

¹⁾ At 100 K ²⁾ Max. 200 ms

Italics: data for motors with EQN 1325 (rated torque reduced by 10%)

Rotatable connections

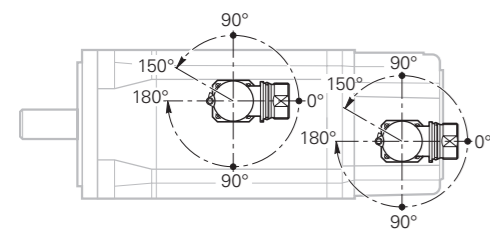

Power connector

For motors with ERN 1387, EQN 1325

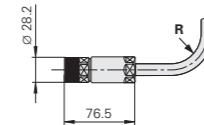

For motor with EQN 1337

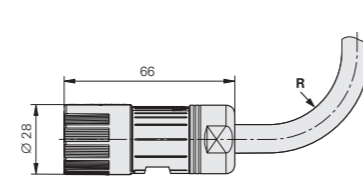

Encoder connector

For motors with ERN 1387, EQN 1325

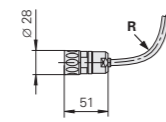

For **R** see page 32

For motor with EQN 1337

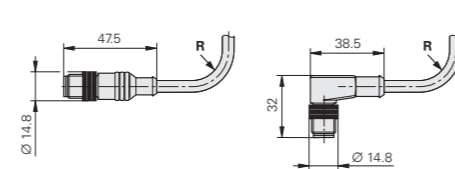

QSY 96A Without brake

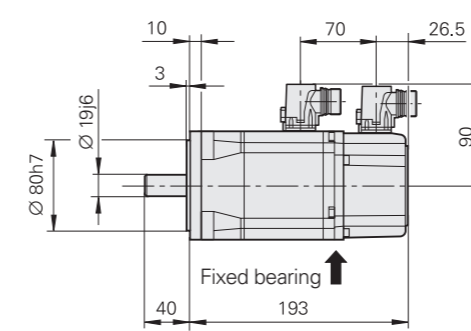

With brake

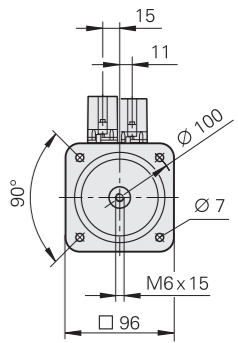
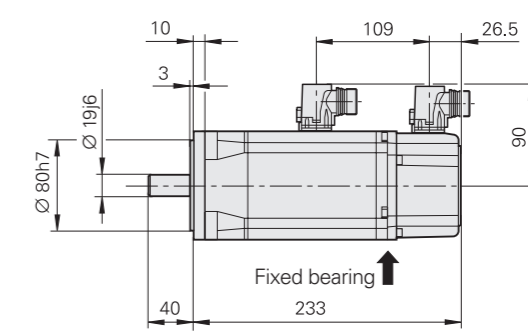

QSY 96A (with EQN 1337) Without brake

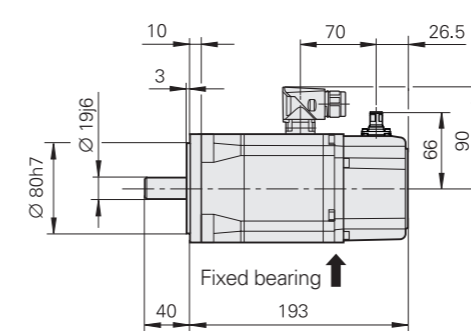

With brake

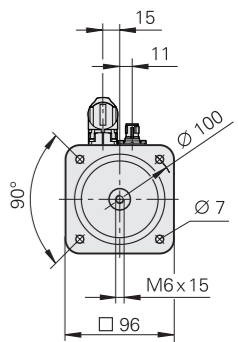
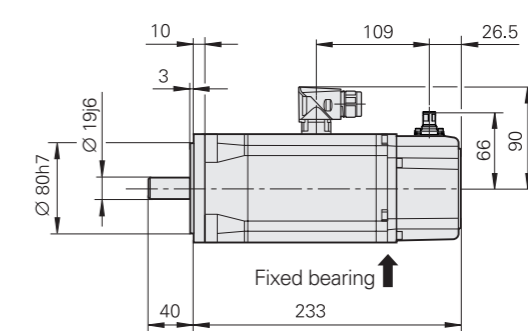

QSY 96G Without brake

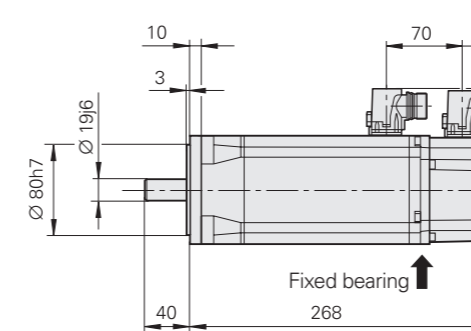

With brake

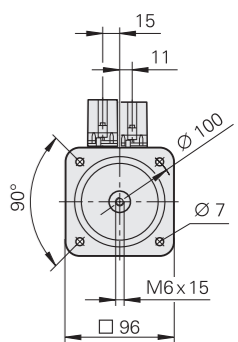
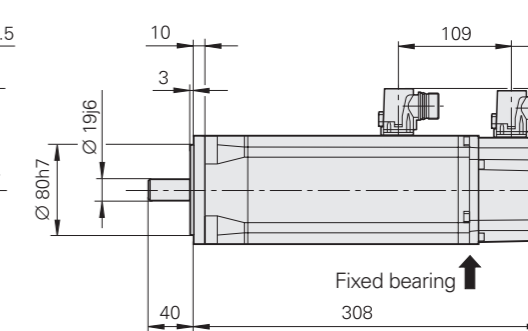

QSY 96G (with EQN 1337) Without brake

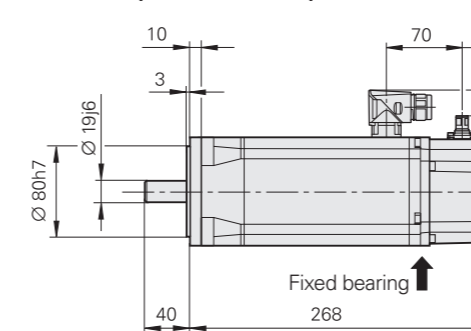

With brake

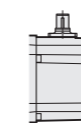
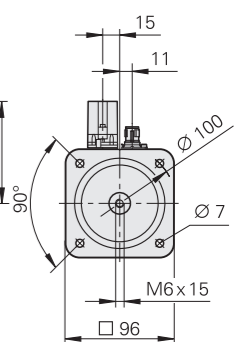
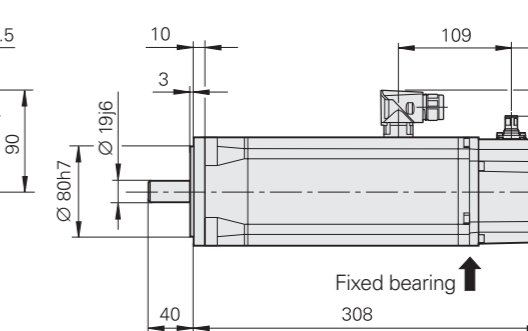

M12 connector for motor-side speed encoder



M23 connector for motor-side speed encoder

mm
Tolerancing ISO 8015
ISO 2768:1989-mH
≤ 6 mm: ±0.2 mm

Synchronous motors

QSY 116 series

Feed motors with three pole pairs

- Stall torque: 5.2 Nm to 10 Nm
- Choice of incremental or absolute rotary encoder



Motor	QSY 116C	QSY 116E	QSY 116J	QSY 116J EcoDyn				
Rated voltage U_N	315 V/311 V	302 V/299 V	290 V/288 V	408 V/405 V				
Rated power output P_N	1.45 kW/1.30 kW	1.85 kW/1.67 kW	2.42 kW/2.18 kW	2.64 kW/2.38 kW				
Rated speed n_N	3000 rpm			3000 rpm ³⁾				
Rated torque M_N¹⁾	4.6 Nm/4.1 Nm	5.9 Nm/5.3 Nm	7.7 Nm/6.9 Nm	8.4 Nm/7.6 Nm				
Rated current I_N¹⁾	3.3 A/3.0 A	4.1 A/3.7 A	5.4 A/4.8 A	4.3 A/3.9 A				
Stall torque M₀¹⁾	5.2 Nm	7.2 Nm	10.0 Nm	10.0 Nm				
Stall current I₀¹⁾	3.3 A	4.8 A	6.8 A	5.0 A				
Max. speed n_{max}	5400 rpm			4200 rpm ³⁾				
Max. torque M_{max}²⁾	16 Nm	25 Nm	41 Nm	41 Nm				
Max. current I_{max}²⁾	12.7 A	19.0 A	32.6 A	23.0 A				
Brake	Without	With	Without	With	Without	With	Without	With
Rated voltage U _{Br}	–	DC 24 V	–	DC 24 V	–	DC 24 V	–	DC 24 V
Rated current I _{Br}	–	0.6 A	–	0.6 A	–	0.85 A	–	0.85 A
Holding torque M _{Br}	–	13.5 Nm	–	13.5 Nm	–	13.5 Nm	–	13.5 Nm
Mass m	6.9 kg	7.8 kg	8.6 kg	9.5 kg	12.0 kg	13.3 kg	12.0 kg	13.3 kg
Rotor inertia J	7.5 kg·cm ²	7.9 kg·cm ²	9.9 kg·cm ²	10.3 kg·cm ²	15.0 kg·cm ²	15.4 kg·cm ²	15.0 kg·cm ²	15.4 kg·cm ²
ID								
Motor with ERN 1387	339876-0C	339876-0D	339877-0C	339877-0D	339878-0C	339878-0D	339878-1C	339878-1D
Motor with EQN 1325	339876-5C	339876-5D	339877-5C	339877-5D	339878-5C	339878-5D	339878-6C	339878-6D
Motor with EQN 1337	339876-4C	339876-4D	339877-4C	339877-4D	339878-4C	339878-4D	339878-3C	339878-3D

¹⁾ At 100 K ²⁾ Max. 200 ms ³⁾ In EcoDyn mode
Italics: data for motors with EQN 1325 (rated torque reduced by 10%)

Rotatable connections

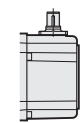
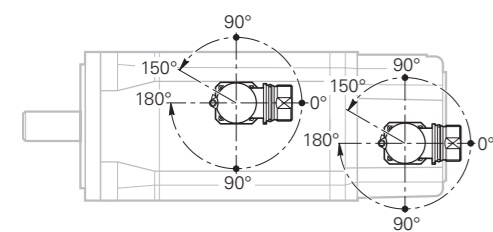

M12 connector for motor-side speed encoder

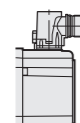

M23 connector for motor-side speed encoder

Power connector

For motors with ERN 1387, EQN 1325

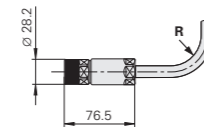

Encoder connector

For motors with ERN 1387, EQN 1325

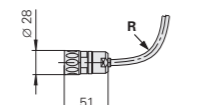

For R see page 32

For motor with EQN 1337

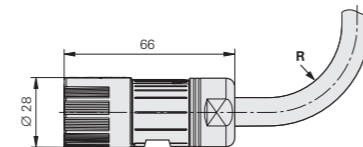

For motor with EQN 1337

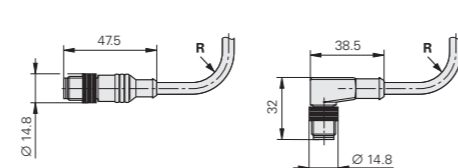

QSY 116C Without brake

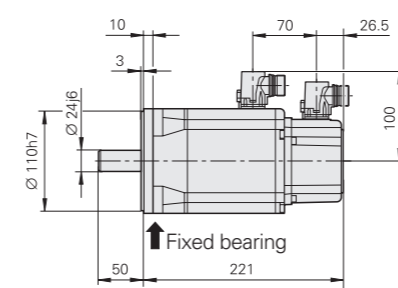

With brake

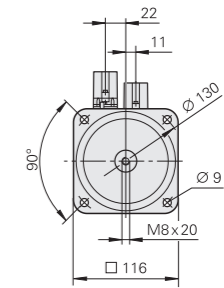
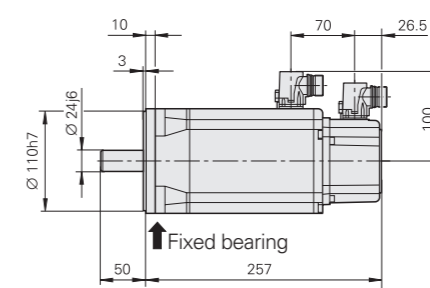

QSY 116C (with EQN 1337) Without brake

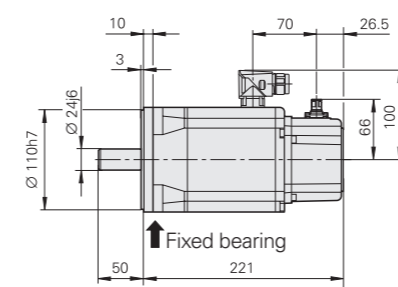

With brake

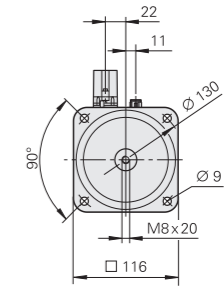
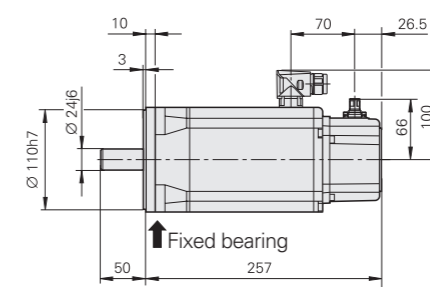

QSY 116E Without brake

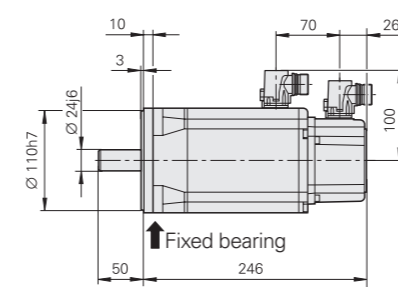

With brake

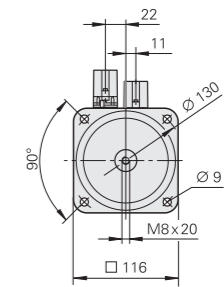
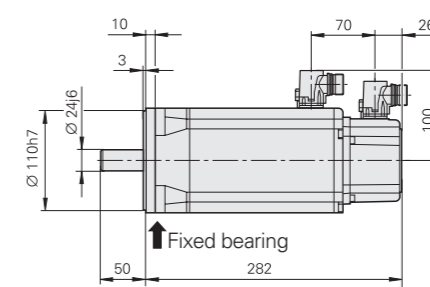

QSY 116E (with EQN 1337) Without brake

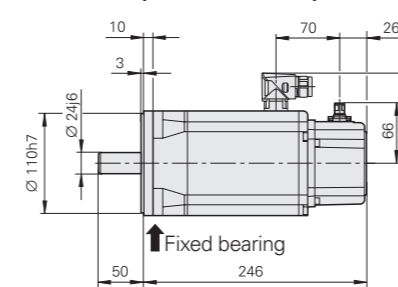

With brake

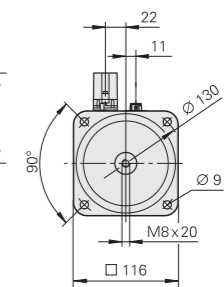
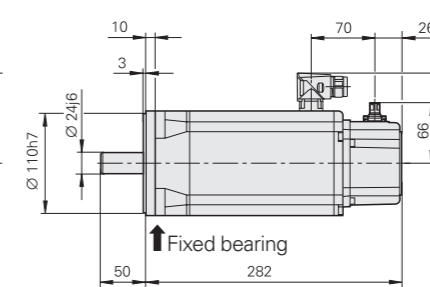

QSY 116J

QSY 116J EcoDyn Without brake

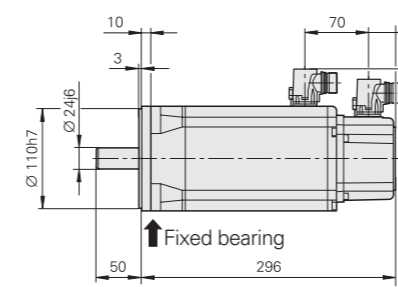

With brake

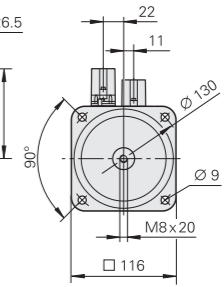
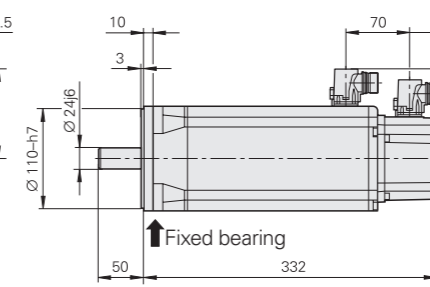

QSY 116J (with EQN 1337)

QSY 116J EcoDyn (with EQN 1337) Without brake With brake

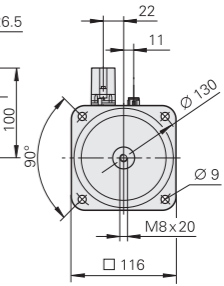
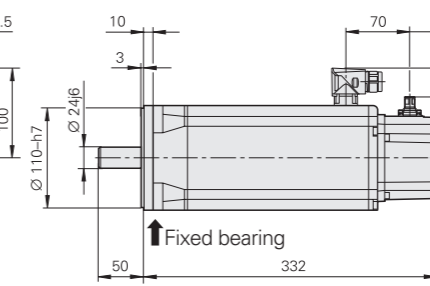
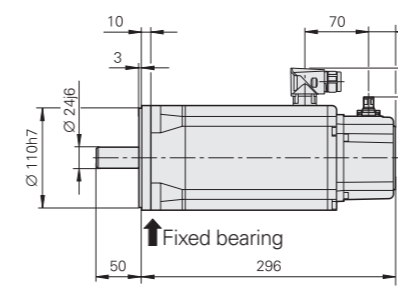

mm
 Tolerancing ISO 8015
 ISO 2768:1989-mH
 ≤ 6 mm: ±0.2 mm

Synchronous motors

QSY 130 EcoDyn series

Feed motors with four pole pairs

- Stall torque: 6 Nm and 9 Nm
- Choice of incremental or absolute rotary encoder



Motor	QSY 130C EcoDyn		QSY 130E EcoDyn	
Rated voltage U_N	415 V/411 V		407 V/403 V	
Rated power output P_N	1.6 kW/1.5 kW		2.3 kW/2.1 kW	
Rated speed n_N	3000 rpm (in EcoDyn mode)			
Rated torque $M_N^{1)}$	5.2 Nm/4.7 Nm		7.4 Nm/6.7 Nm	
Rated current $I_N^{1)}$	2.7 A/2.4 A		3.8 A/3.4 A	
Stall torque $M_0^{1)}$	6 Nm		9 Nm	
Stall current $I_0^{1)}$	3.0 A		4.5 A	
Maximum speed n_{max}	4200 rpm (in EcoDyn mode)			
Max. torque $M_{max}^{2)}$	16 Nm		23 Nm	
Max. current $I_{max}^{2)}$	8.6 A		12.7 A	
Brake	Without	With	Without	With
Rated voltage U_{Br}	–	DC 24 V	–	DC 24 V
Rated current I_{Br}	–	0.6 A	–	0.6 A
Holding torque M_{Br}	–	13.5 Nm	–	13.5 Nm
Mass m	7.9 kg	8.8 kg	9.7 kg	10.6 kg
Rotor inertia J	16.0 kg·cm ²	16.4 kg·cm ²	21.0 kg·cm ²	21.4 kg·cm ²
ID				
Motor with ERN 1387	389053-1C	389053-1D	388422-1C	388422-1D
Motor with EQN 1325	389053-6C	389053-6D	388422-6C	388422-6D
Motor with EQN 1337	389053-3C	389053-3D	388422-3C	388422-3D

¹⁾ At 100 K ²⁾ Max. 200 ms
Italics: data for motors with EQN 1325 (rated torque reduced by 10%)

Rotatable connections

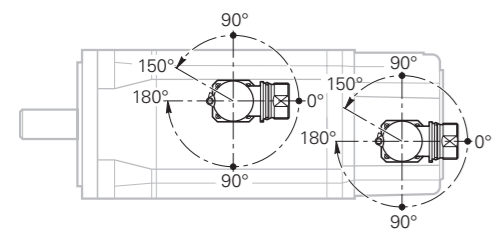

Power connector

For motors with ERN 1387, EQN 1325

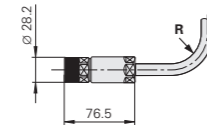

Encoder connector

For motors with ERN 1387, EQN 1325

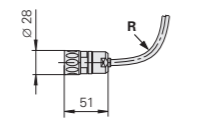

For **R** see page 32

For motor with EQN 1337

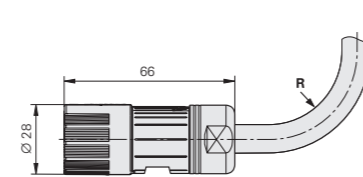

For motor with EQN 1337

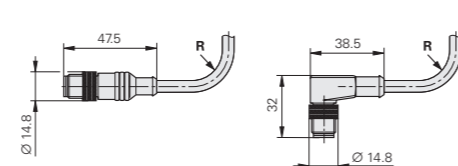

QSY 130C Without brake

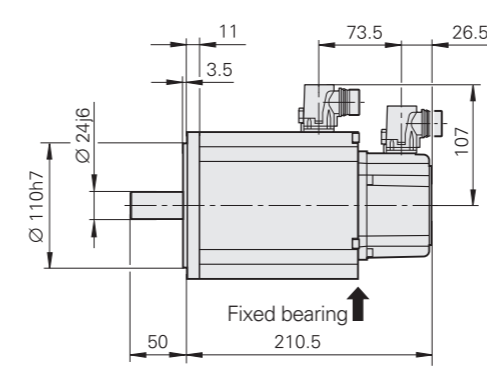

With brake

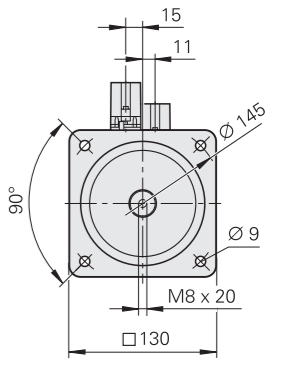
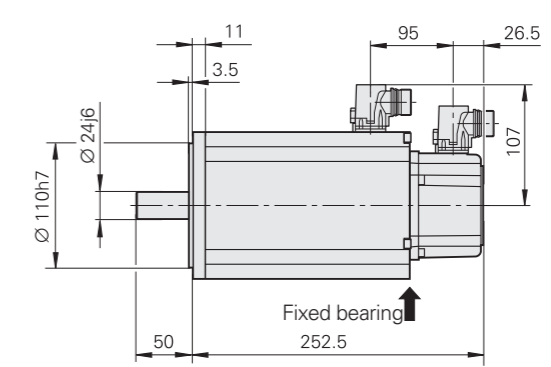

QSY 130C EcoDyn (with EQN 1337) Without brake

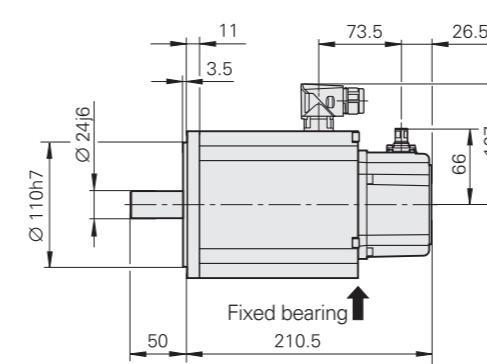

With brake

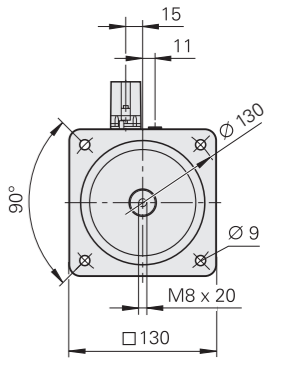
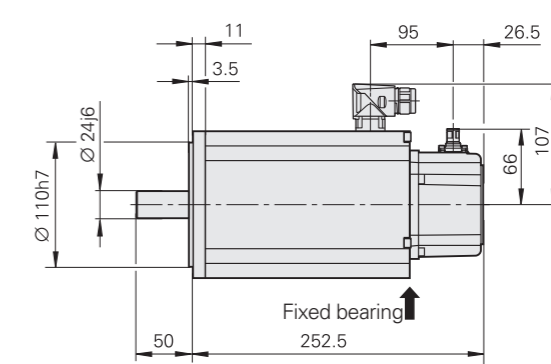

QSY 130E Without brake

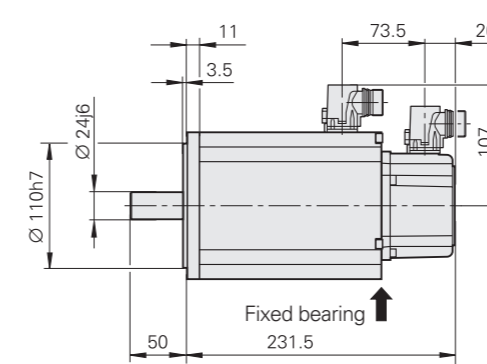

With brake

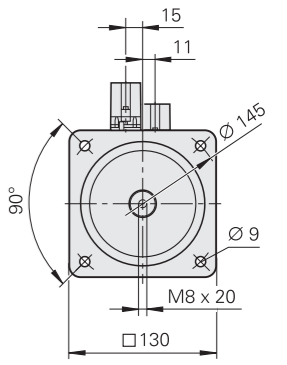
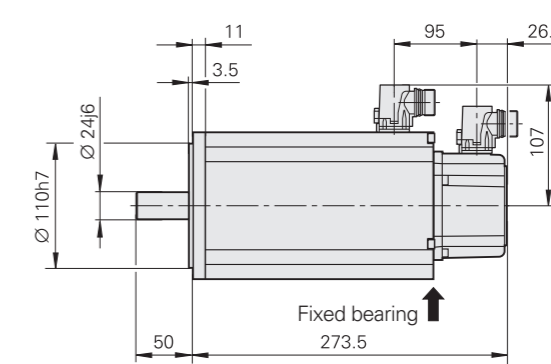

QSY 130E (with EQN 1337) Without brake

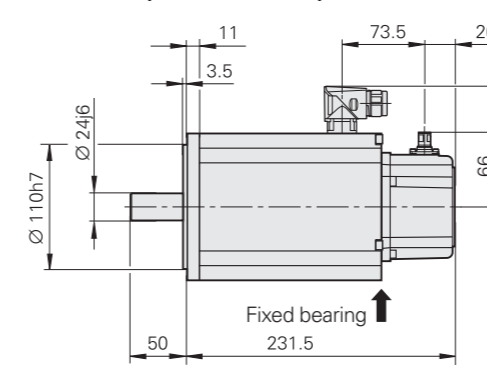

With brake

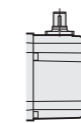
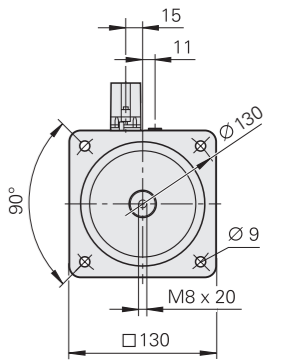
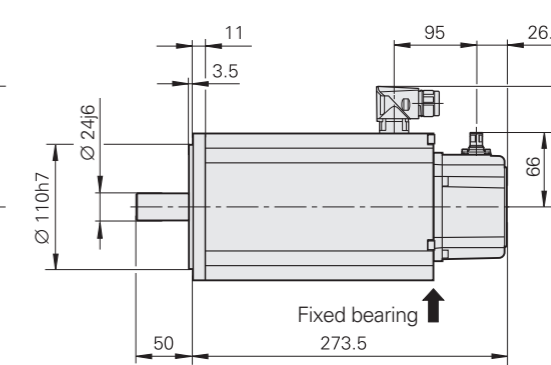

M12 connector for motor-side speed encoder



M23 connector for motor-side speed encoder

mm
 Tolerancing ISO 8015
 ISO 2768:1989-mH
 ≤ 6 mm: ±0.2 mm

Synchronous motors

QSY 155 series

Feed motors with four pole pairs

- Stall torque: 13 Nm to 26.1 Nm
- Choice of incremental or absolute rotary encoder



Motor	QSY 155B	QSY 155C	QSY 155D	QSY 155F				
Rated voltage U_N	298 V/295 V	294 V/291 V	293 V/291 V	289 V/287 V				
Rated power output P_N	2.9 kW/2.6 kW	3.9 kW/3.5 kW	4.6 kW/4.1 kW	5.2 kW/4.7 kW				
Rated speed n_N	3000 rpm							
Rated torque $M_N^{1)}$	9.2 Nm/8.3 Nm	12.5 Nm/11.3 Nm	14.8 Nm/13.3 Nm	16.7 Nm/15.0 Nm				
Rated current $I_N^{1)}$	6.9 A/6.2 A	8.7 A/7.8 A	10.6 A/9.5 A	12.0 A/10.8 A				
Stall torque $M_0^{1)}$	13.0 Nm	17.7 Nm	21.6 Nm	26.1 Nm				
Stall current $I_0^{1)}$	9.1 A	11.8 A	14.6 A	18.0 A				
Maximum speed n_{max}	5000 rpm							
Max. torque $M_{max}^{2)}$	39 Nm	52 Nm	64 Nm	90 Nm				
Max. current $I_{max}^{2)}$	29.7 A	38.9 A	49.5 A	68.6 A				
Brake	Without	With	Without	With	Without	With	Without	With
Rated voltage U_{Br}	-	DC 24 V	-	DC 24 V	-	DC 24 V	-	DC 24 V
Rated current I_{Br}	-	1.17 A	-	1.17 A	-	1.17 A	-	1.17 A
Holding torque M_{Br}	-	40 Nm	-	40 Nm	-	40 Nm	-	40 Nm
Mass m	15.0 kg	18.0 kg	17.5 kg	20.5 kg	20.0 kg	23.0 kg	25.0 kg	28.0 kg
Rotor inertia J	33 kg·cm ²	35 kg·cm ²	43 kg·cm ²	45 kg·cm ²	54 kg·cm ²	56 kg·cm ²	75 kg·cm ²	77 kg·cm ²
ID								
Motor with ERN 1387	1378139-03	1378139-04	1378140-03	1378140-04	1378141-03	1378141-04	1378142-03	1378142-04
Motor with EQN 1325	1378139-53	1378139-54	1378140-53	1378140-54	1378141-53	1378141-54	1378142-53	1378142-54
Motor with EQN 1337	1378139-43	1378139-44	1378140-43	1378140-44	1378141-43	1378141-44	1378142-43	1378142-44

¹⁾ At 100 K ²⁾ Max. 200 ms

Italics: data for motors with EQN 1325 or EQN 1337 (rated torque reduced by 10%)

Rotatable connections

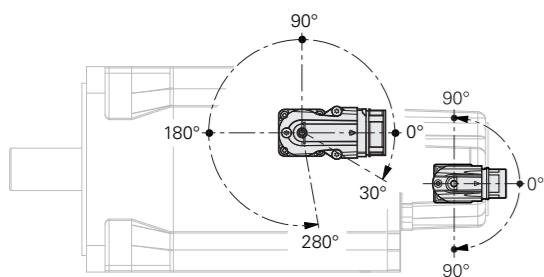

Power connector

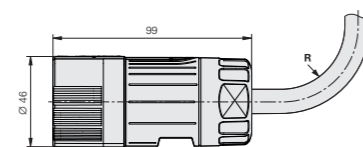

Encoder connector

For motors with ERN 1387, EQN 1325

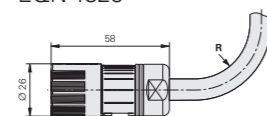

For **R** see page 32

For motor with EQN 1337

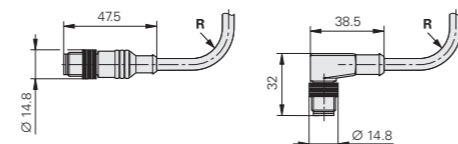

QSY 155B Without brake

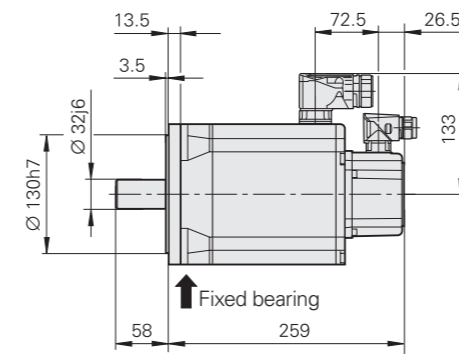

With brake

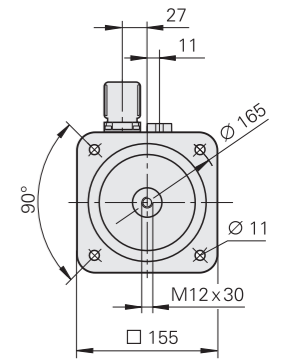
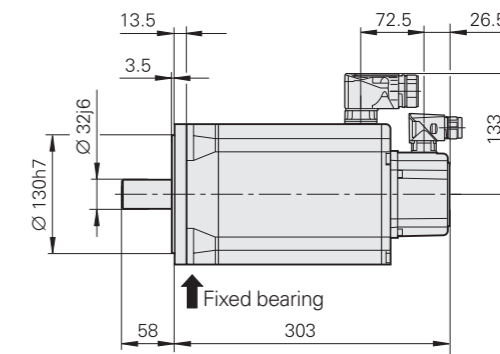

QSY 155C Without brake

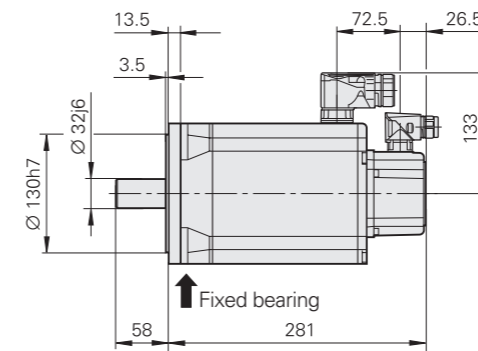

With brake

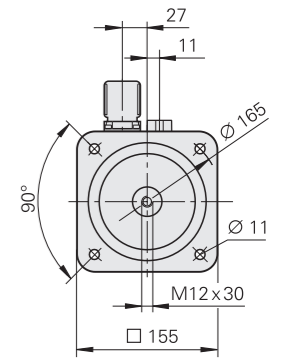
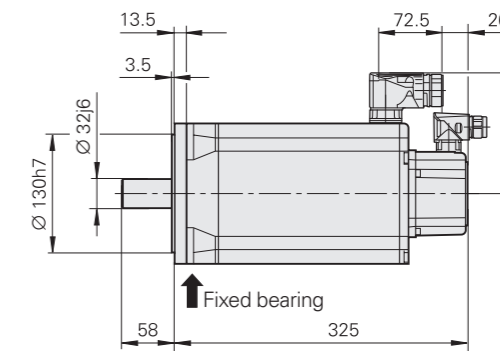

QSY 155D Without brake

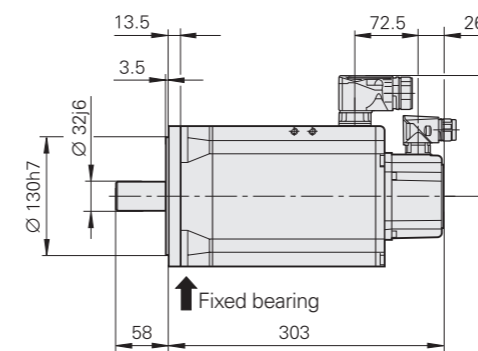

With brake

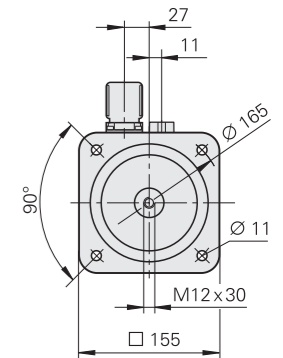
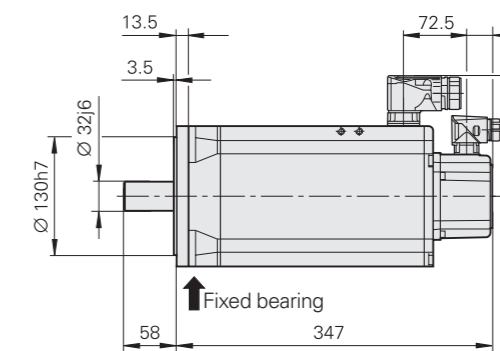

QSY 155F Without brake

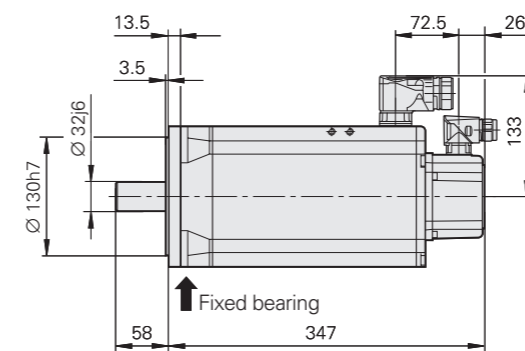

With brake

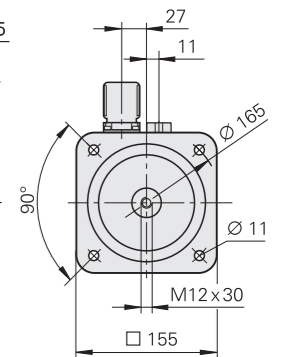
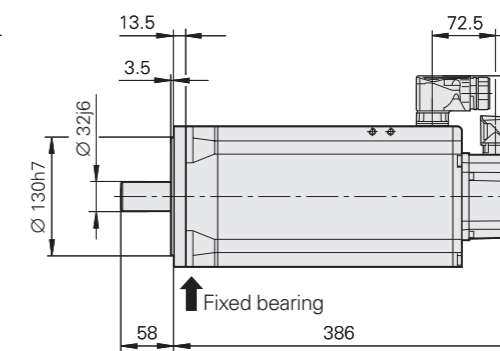

M12 connector for motor-side speed encoder



M23 connector for motor-side speed encoder

mm
Tolerancing ISO 8015
ISO 2768:1989-mH
≤ 6 mm: ±0.2 mm

Synchronous motors

QSY 155 EcoDyn series

- Feed motors with four pole pairs
- Stall torque: 13 Nm to 26.1 Nm
 - Choice of incremental or absolute rotary encoder

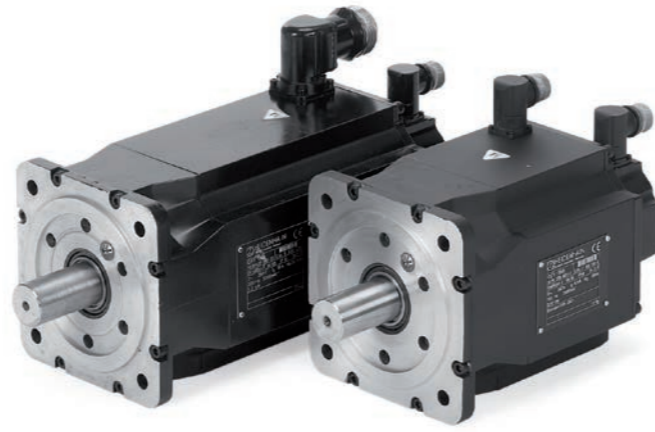

Motor	QSY 155B EcoDyn	QSY 155C EcoDyn	QSY 155D EcoDyn	QSY 155F EcoDyn				
Rated voltage U_N	417 V/412 V	420 V/415 V	412 V/407 V	399 V/397 V				
Rated power output P_N	3.5 kW/3.1 kW	5.0 kW/4.5 kW	5.7 kW/5.1 kW	6.0 kW/5.4 kW				
Rated speed n_N	3000 rpm (in EcoDyn mode)							
Rated torque $M_N^{1)}$	11.0 Nm/9.9 Nm	16.0 Nm/14.4 Nm	18.1 Nm/16.3 Nm	19.2 Nm/17.3 Nm				
Rated current $I_N^{1)}$	5.6 A/5.0 A	8.2 A/7.4 A	9.1 A/8.2 A	9.8 A/8.8 A				
Stall torque $M_0^{1)}$	13.0 Nm	17.7 Nm	21.6 Nm	26.1 Nm				
Stall current $I_0^{1)}$	6.5 A	8.5 A	10.6 A	12.8 A				
Maximum speed n_{max}	4200 rpm (in EcoDyn mode)							
Max. torque $M_{max}^{2)}$	39 Nm	52 Nm	64 Nm	90 Nm				
Max. current $I_{max}^{2)}$	21.2 A	27.6 A	35.0 A	49.5 A				
Brake	Without	With	Without	With	Without	With	Without	With
Rated voltage U_{Br}	-	DC 24 V	-	DC 24 V	-	DC 24 V	-	DC 24 V
Rated current I_{Br}	-	1.17 A	-	1.17 A	-	1.17 A	-	1.17 A
Holding torque M_{Br}	-	40 Nm	-	40 Nm	-	40 Nm	-	40 Nm
Mass m	15.0 kg	18.0 kg	17.5 kg	20.5 kg	20.0 kg	23.0 kg	25.0 kg	28.0 kg
Rotor inertia J	33 kg·cm ²	35 kg·cm ²	43 kg·cm ²	45 kg·cm ²	54 kg·cm ²	56 kg·cm ²	75 kg·cm ²	77 kg·cm ²
ID								
Motor with ERN 1387	1378139-13	1378139-14	1378140-13	1378140-14	1378141-13	1378141-14	1378142-13	1378142-14
Motor with EQN 1325	1378139-63	1378139-64	1378140-63	1378140-64	1378141-63	1378141-64	1378142-63	1378142-64
Motor with EQN 1337	1378139-33	1378139-34	1378140-33	1378140-34	1378141-33	1378141-34	1378142-33	1378142-34

¹⁾ At 100 K ²⁾ Max. 200 ms
Italics: data for motors with EQN 1325 or EQN 1337 (rated torque reduced by 10%)

Rotatable connections

For QSY 155 B/C/D

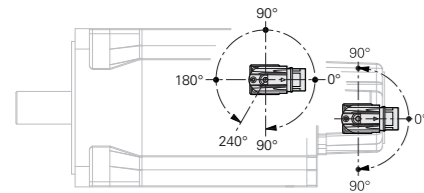

For QSY 155 F

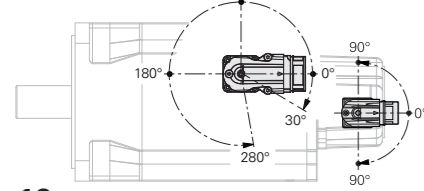

Power connector

For QSY 155 B/C/D EcoDyn

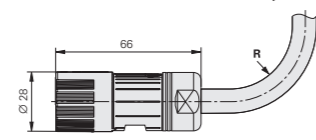

For QSY 155 F EcoDyn

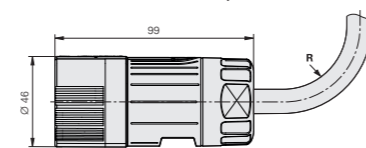

Encoder connector

For motors with ERN 1387, EQN 1325

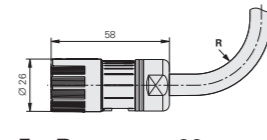

For **R** see page 32

For motor with EQN 1337

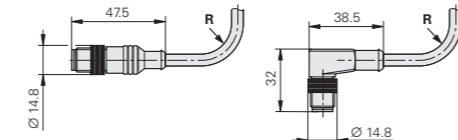

QSY 155B EcoDyn Without brake

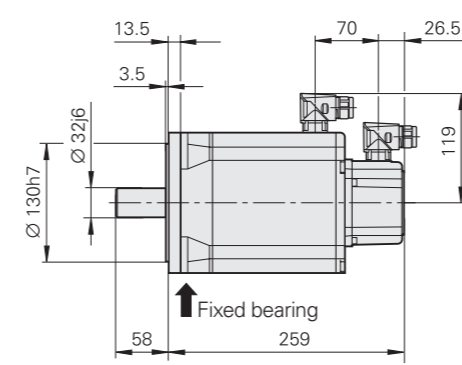

With brake

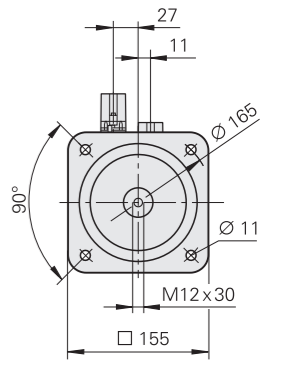
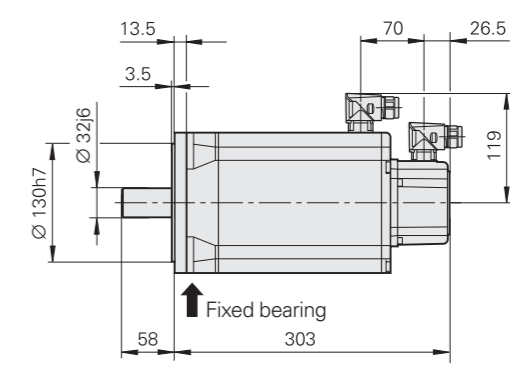

QSY 155C EcoDyn Without brake

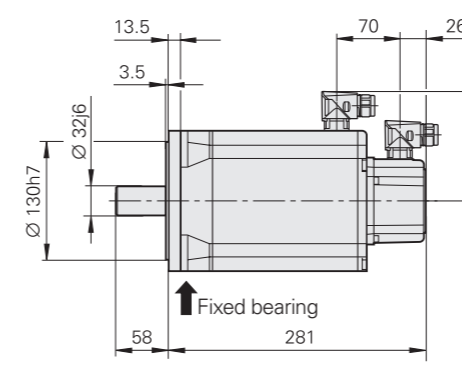

With brake

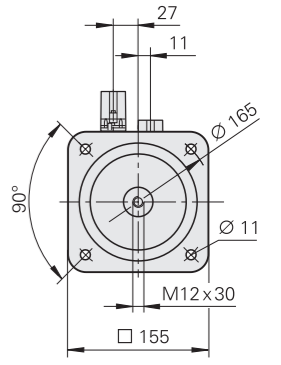
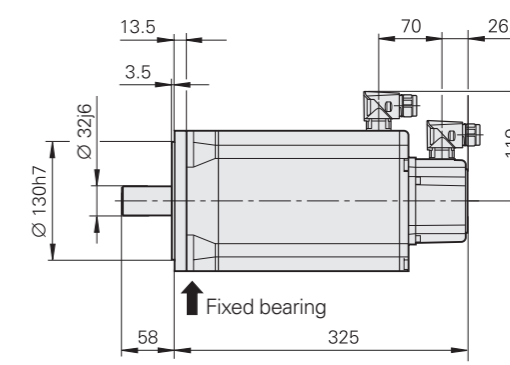

QSY 155D EcoDyn Without brake

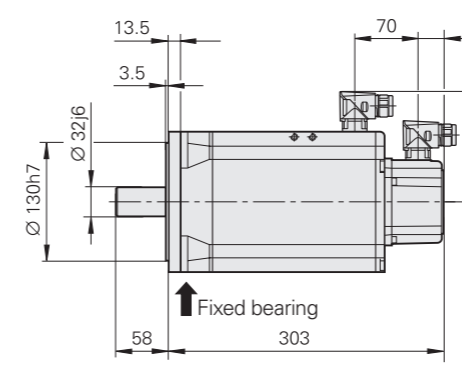

With brake

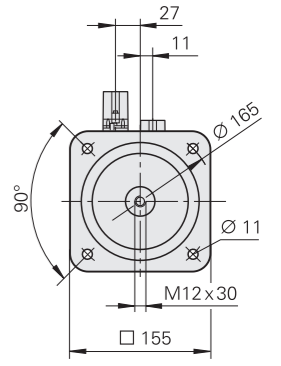
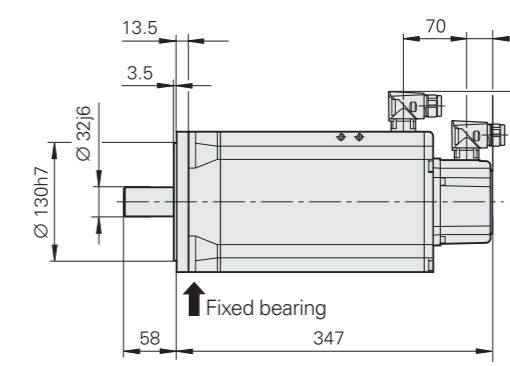

QSY 155F EcoDyn Without brake

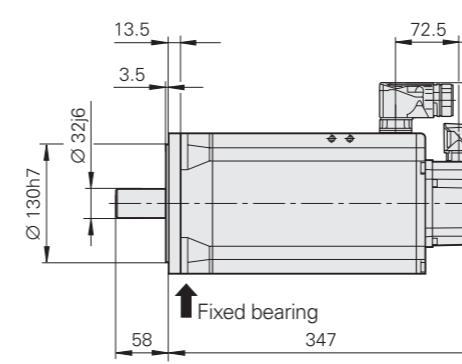

With brake

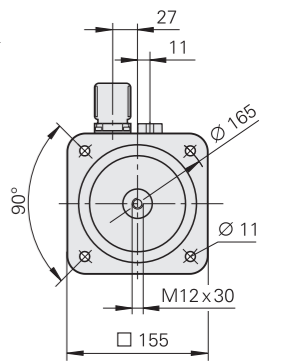
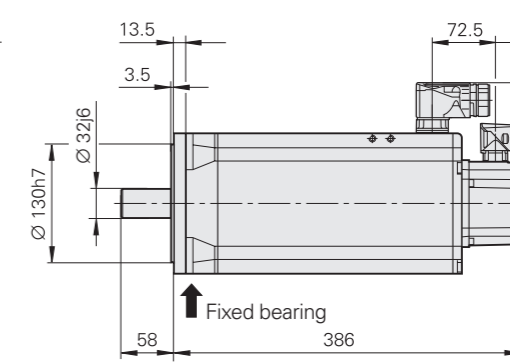

M12 connector for motor-side speed encoder



M23 connector for motor-side speed encoder

mm
 Tolerancing ISO 8015
 ISO 2768:1989-mH
 ≤ 6 mm: ±0.2 mm

Synchronous motors

QSY 190 EcoDyn series

- Feed motors with four pole pairs
- Stall torque: 28 Nm to 62.5 Nm
 - Choice of incremental or absolute rotary encoder



Motor	QSY 190C EcoDyn	QSY 190D EcoDyn	QSY 190F EcoDyn	QSY 190K EcoDyn				
Rated voltage U_N	427 V/420 V	421 V/412 V	408 V/404 V	399 V/396 V				
Rated power output P_N	7.2 kW/6.5 kW	9.6 kW/8.6 kW	9.9 kW/8.9 kW	12.2 kW/11.0 kW				
Rated speed n_N	3000 rpm (in EcoDyn mode)							
Rated torque $M_N^{1)}$	23.0 Nm/20.7 Nm	30.6 Nm/27.5 Nm	31.5 Nm/28.4 Nm	39.0 Nm/35.1 Nm				
Rated current $I_N^{1)}$	11.8 A/10.6 A	14.4 A/13.0 A	15.0 A/13.5 A	20.2 A/18.2 A				
Stall torque $M_0^{1)}$	28.0 Nm	38.0 Nm	47.6 Nm	62.5 Nm				
Stall current $I_0^{1)}$	14.0 A	18.1 A	22.7 A	29.8 A				
Maximum speed n_{max}	3900 rpm (in EcoDyn mode)							
Max. torque $M_{max}^{2)}$	85 Nm	107 Nm	150 Nm	240 Nm				
Max. current $I_{max}^{2)}$	50.2 A	62.9 A	88.4 A	134.3 A				
Brake	Without	With	Without	With	Without	With	Without	With
Rated voltage U_{Br}	-	DC 24 V	-	DC 24 V	-	DC 24 V	-	DC 24 V
Rated current I_{Br}	-	1.38 A	-	1.38 A	-	1.38 A	-	1.38 A
Holding torque M_{Br}	-	70 Nm	-	70 Nm	-	70 Nm	-	70 Nm
Mass m	29.0 kg	37.0 kg	33.5 kg	41.5 kg	42.5 kg	50.5 kg	61.0 kg	69.0 kg
Rotor inertia J	106 kg·cm ²	115 kg·cm ²	133 kg·cm ²	142 kg·cm ²	190 kg·cm ²	199 kg·cm ²	290 kg·cm ²	299 kg·cm ²
ID								
Motor with ERN 1387	1378156-13	1378156-14	1378157-13	1378157-14	1378158-13	1378158-14	1378159-13	1378159-14
Motor with EQN 1325	1378156-63	1378156-64	1378157-63	1378157-64	1378158-63	1378158-64	1378159-63	1378159-64
Motor with EQN 1337	1378156-33	1378156-34	1378157-33	1378157-34	1378158-33	1378158-34	1378159-33	1378159-34

¹⁾ At 100 K ²⁾ Max. 200 ms
Italics: data for motors with EQN 1325 or EQN 1337 (rated torque reduced by 10%)

Rotatable connections

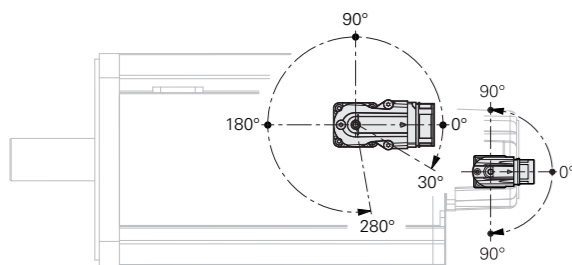

Power connector

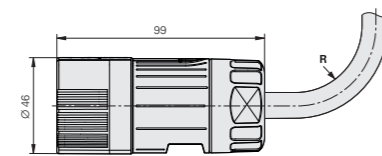

Encoder connector

For motors with ERN 1387, EQN 1325

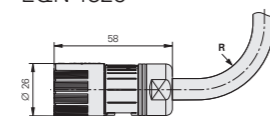

For R see page 32

For motor with EQN 1337

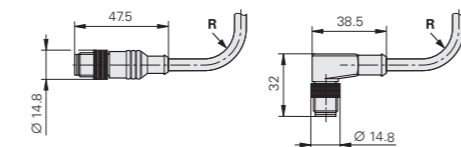

QSY 190C EcoDyn Without brake

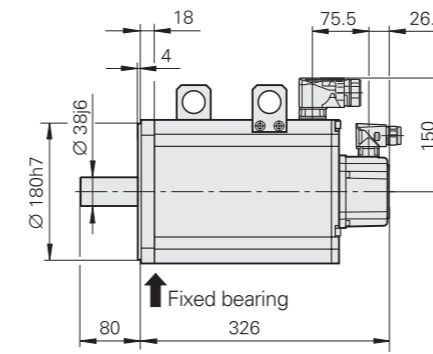

With brake

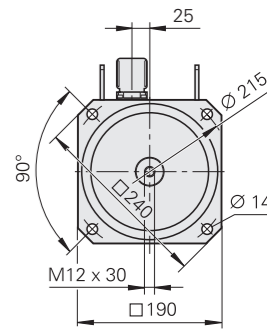
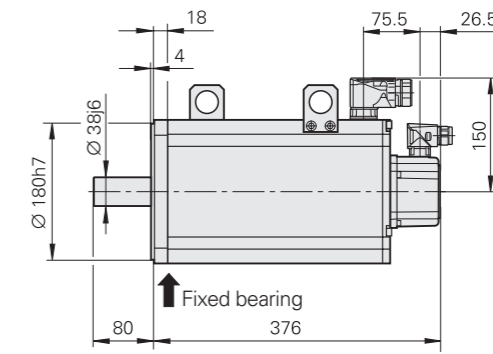

QSY 190D EcoDyn Without brake

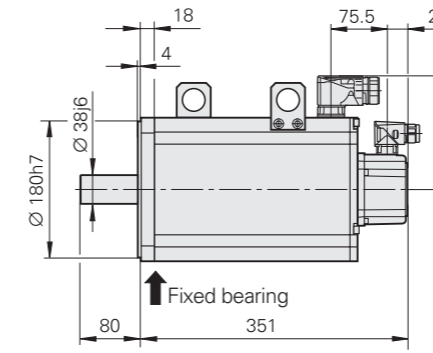

With brake

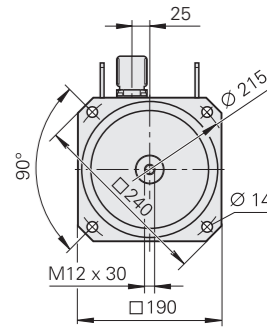
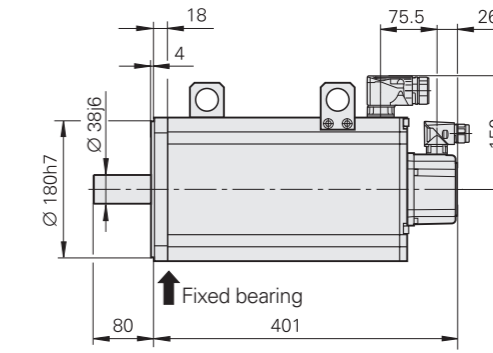

QSY 190F EcoDyn Without brake

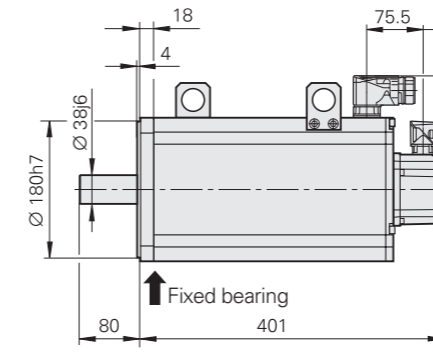

With brake

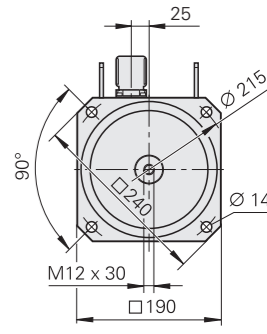
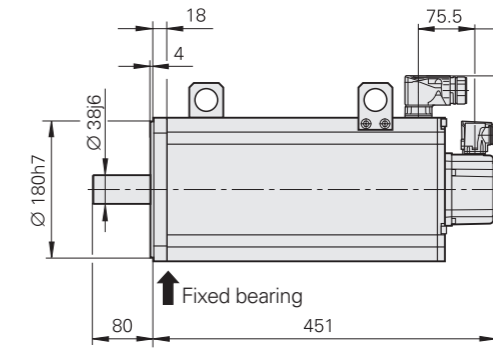

QSY 190K EcoDyn Without brake

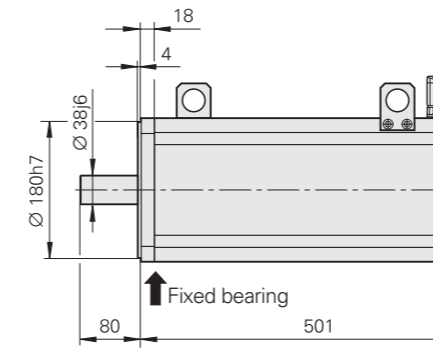

With brake

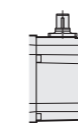
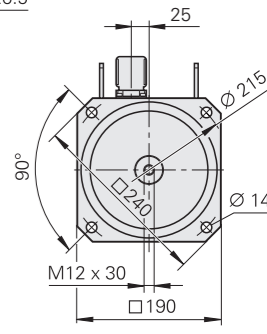
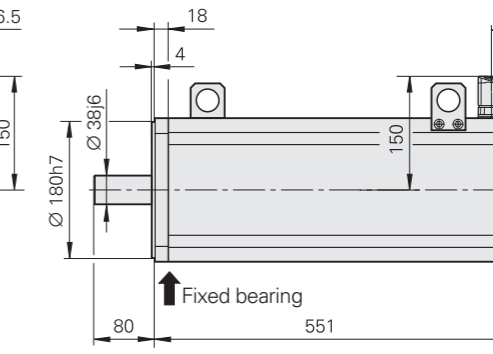

M12 connector for motor-side speed encoder



M23 connector for motor-side speed encoder

mm
 Tolerancing ISO 8015
 ISO 2768:1989-mH
 ≤ 6 mm: ±0.2 mm

Synchronous motors

QSY 260 EcoDyn series

- Feed motors with four pole pairs
- Stall torque: 85 Nm to 120 Nm
 - Choice of incremental or absolute rotary encoder



Motor	QSY 260B EcoDyn		QSY 260C EcoDyn	
Rated voltage U_N	352 V/350 V		376 V/373 V	
Rated power output P_N	12.0 kW/10.8 kW		16.0 kW/14.4 kW	
Rated speed n_N	2000 rpm (in EcoDyn mode)			
Rated torque $M_N^{1)}$	57.3 Nm/51.6 Nm		76.4 Nm/68.8 Nm	
Rated current $I_N^{1)}$	21.5 A/19.4 A		28 A/25.2 A	
Stall torque $M_0^{1)}$	85 Nm		120 Nm	
Stall current $I_0^{1)}$	31.0 A		43.5 A	
Maximum speed n_{max}	3000 rpm (in EcoDyn mode)			
Max. torque $M_{max}^{2)}$	250 Nm		360 Nm	
Max. current $I_{max}^{2)}$	130 A		173 A	
Brake	Without	With	Without	With
Rated voltage U_{Br}	–	DC 24 V	–	DC 24 V
Rated current I_{Br}	–	2.05 A	–	2.05 A
Holding torque M_{Br}	–	110 Nm	–	125 Nm
Mass m	62 kg	75 kg	74 kg	87 kg
Rotor inertia J	357 kg·cm ²	368 kg·cm ²	538 kg·cm ²	557 kg·cm ²
ID				
Motor with ERN 1387	1110623-1C	1110623-1D	1100242-1C	1100242-1D
Motor with EQN 1325	1110623-6C	1110623-6D	1100242-6C	1100242-6D
Motor with EQN 1337	1110623-3C	1110623-3D	1100242-3C	1100242-3D

¹⁾ At 100 K ²⁾ Max. 200 ms
Italics: data for motors with EQN 1325 (rated torque reduced by 10%)

Rotatable connections

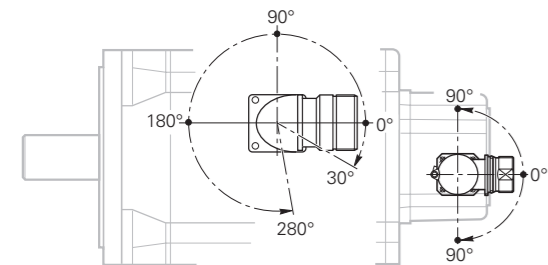

Power connector

For motors with ERN 1387, EQN 1325

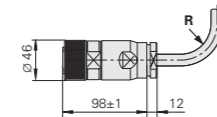

Encoder connector

For motors with ERN 1387, EQN 1325

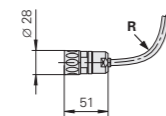

For **R** see page 32

For motor with EQN 1337

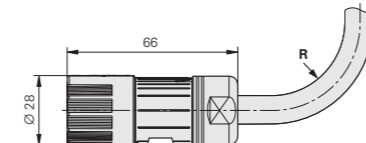

For motor with EQN 1337

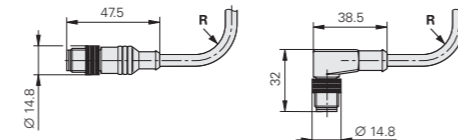

QSY 260B Without brake

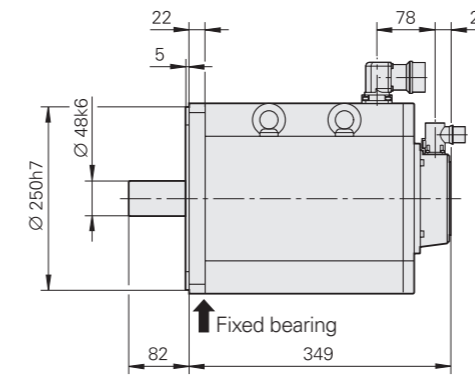

With brake

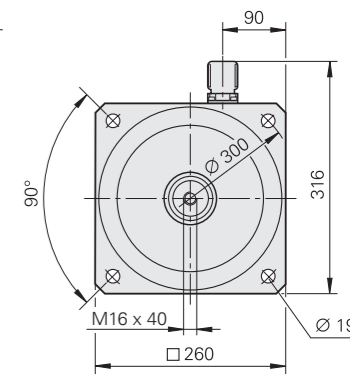
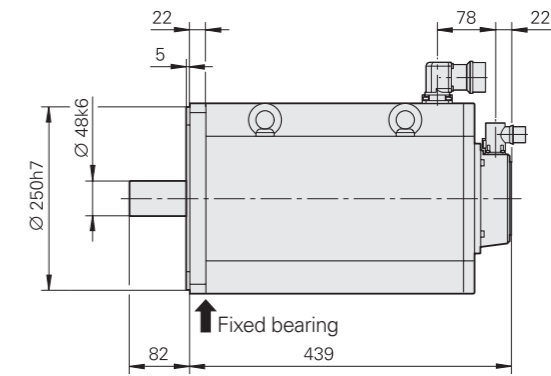

QSY 260B EcoDyn (with EQN 1337) Without brake

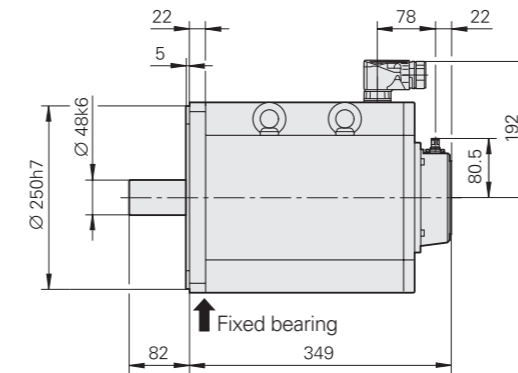

With brake

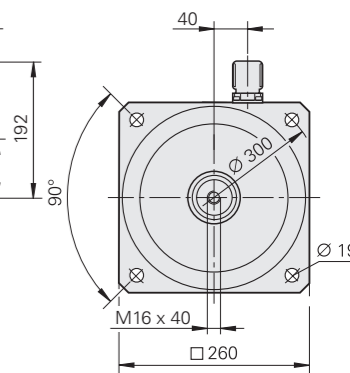
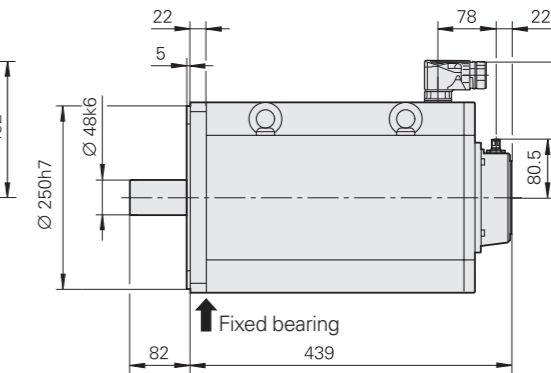

QSY 260C Without brake

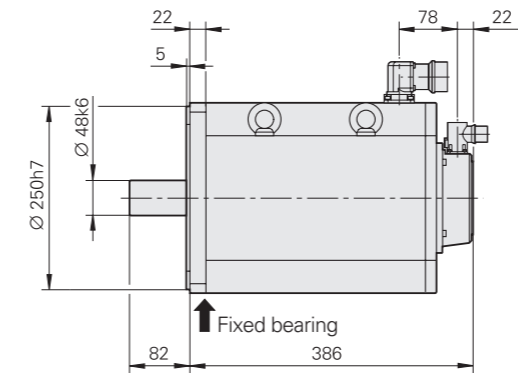

With brake

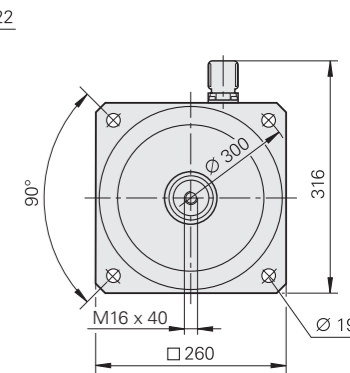
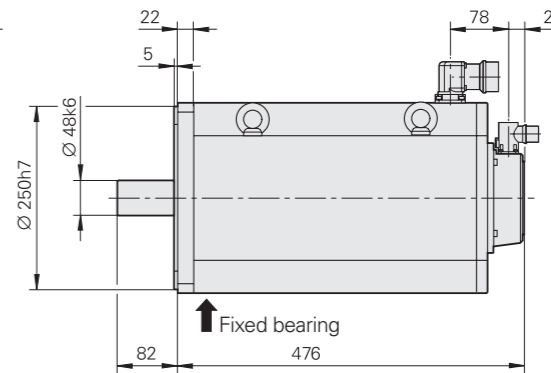

QSY 260C EcoDyn (with EQN 1337) Without brake

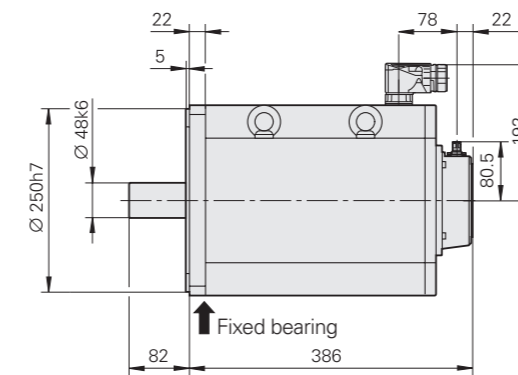

With brake

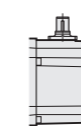
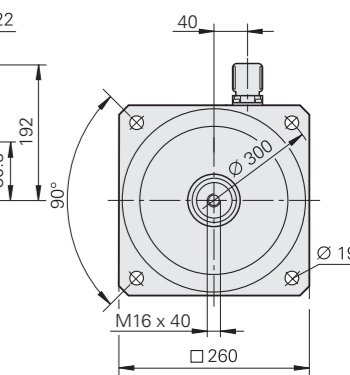
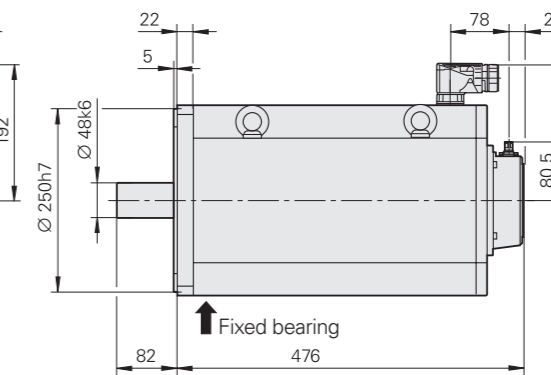

M12 connector for motor-side speed encoder



M23 connector for motor-side speed encoder

mm
 Tolerancing ISO 8015
 ISO 2768:1989-mH
 ≤ 6 mm: ±0.2 mm

Synchronous motors

MSY overview

General technical information

HEIDENHAIN MSY servomotors are compact synchronous motors with high dynamic performance for use in machine tools. Thanks to their robust control properties, their excellent speed stability and the moment of inertia perfectly adapted to the application, they are particularly well suited for medium to high-performance feed drives and auxiliary axes. The MSY servomotors have the following characteristics:

- Short and compact design
- Good speed stability
- Plug-and-play functionality
- High-precision fit brake

Specifications

The permissible operating range of the MSY motor is limited by thermal, mechanical and electromagnetic factors. The values for the motor characteristics and motor specifications apply to an ambient temperature of up to 40 °C.

Speed measurement

Synchronous motors from HEIDENHAIN operate with sinusoidal commutation. An integrated rotary encoder from HEIDENHAIN measures the rotor position and monitors the speed:

- ECI 1323 inductive absolute rotary encoder (singleturn) with functional safety and the EnDat 2.2 interface
- EQI 1335 inductive absolute rotary encoder (multiturn) with functional safety and the EnDat 2.2 interface

Electronic ID label

MSY motors are equipped with the EnDat interface and have electronic ID labels. These enable the control to automatically identify the motor. The information stored in this ID label, such as the motor designation, ID number or serial number, can be read and displayed by the internal TNCdiag diagnostic function of the HSCI controls.

Mechanical service life

HEIDENHAIN motors contain components that are subject to wear, depending on the application and handling. This especially applies to the following parts:

- Bearings
- Brakes
- Radial shaft seal rings

Depending on the usage conditions of the motors, suitable maintenance intervals should be scheduled.

The expected nominal bearing life is 25 000 hours.

Functional safety

The rotary encoders used in the motors feature functional safety and are, in principle, therefore suitable for use in safety-related applications. All motors of the MSY series have a fault exclusion feature that prevents loosening of the mechanical connection between the encoder and the motor. Safety-related parameters for the motors or the encoders used within them are available upon request (e.g., MTTF values, data for fault exclusion).

Installation elevation

HEIDENHAIN motors may be installed at an elevation of up to 1000 m above sea level. For installation at elevations above 1000 m, additional cooling measures are required.

Thermal parameters

The motors are self-cooled, and temperature monitoring of the MSY is performed via a thermal motor model in the HEIDENHAIN control calculated during operation. MSY motors meet the requirements of thermal class F as per DIN EN 60034-1.

Mechanical parameters

Maintenance-free bearings
Holding brake optionally with low backlash $\leq 1^\circ$

The MSY series motors have a mounting flange in accordance with IEC 60072-1. The HEIDENHAIN MSY synchronous motors exist in the configurations IM B5, IM V1 and IM V3 in accordance with DIN EN 60034-7.

Mounting the motor

The following screws are recommended for mounting the motor:

MSY 155	M10
MSY 192	M12

Protection as per DIN EN 60529

The MSY motors feature an IP rating of IP64 at their shaft outlet, and an IP65 rating for the entire rest of the motor.

Vibration severity

MSY motors conform to vibration severity grade A in accordance with EN 60034-14:2008. This is adhered to up to the nominal speed.

Radial runout, concentricity and axial runout
With respect to the flange and shaft precision, MSY motors comply with CEI IEC 72-1:1991-02.

Shaft end

The motors have cylindrical shaft ends with front-face center holes according to DIN 332-2. Optionally, the shaft end is available with a keyway. Shaft with keyway and machine key as per DIN 6885-1 (upon request)

- MSY 155 A 10x8x45
- MSY 192 A 10x8x50

The motors with machine key are half-key balanced as per ISO 21940-32.



MSY 155B



MSY 155E



MSY 192F

Synchronous motors

MSY 155 series

Feed motors with four pole pairs

- Stall torque: 12.8 Nm to 28.9 Nm
- With HEIDENHAIN inductive absolute rotary encoders (singleturn or multiturn) and the purely serial EnDat 2.2 interface



Motor	MSY 155 B	MSY 155 C	MSY 155 D	MSY 155 E				
Rated voltage U_N	299 V	296 V	298 V	305 V				
Rated power output P_N	3.0 kW	3.8 kW	4.5 kW	4.7 kW				
Rated speed n_N	2500 rpm							
Rated torque $M_N^{1)}$	11.4 Nm	14.6 Nm	17.1 Nm	18.0 Nm				
Rated current $I_N^{1)}$	7.2 A	8.8 A	9.9 A	10.0 A				
Stall torque $M_0^{1)}$	12.8 Nm	18.2 Nm	24.1 Nm	28.9 Nm				
Stall current $I_0^{1)}$	7.8 A	10.5 A	13.5 A	15.5 A				
Maximum speed n_{max}	5000 rpm							
Max. torque $M_{max}^{2)}$	38 Nm	53 Nm	67 Nm	84 Nm				
Max. current $I_{max}^{2)}$	24.4 A	30.9 A	36.9 A	44.5 A				
Brake	Without	With	Without	With	Without	With	Without	With
Rated voltage U_{Br}	–	DC 24 V	–	DC 24 V	–	DC 24 V	–	DC 24 V
Rated current I_{Br}	–	1.17 A	–	1.17 A	–	1.17 A	–	1.17 A
Holding torque M_{Br}	–	30 Nm	–	30 Nm	–	30 Nm	–	30 Nm
Mass m	12 kg	15 kg	15 kg	18 kg	18 kg	20 kg	20 kg	23 kg
Rotor inertia J	21 kg·cm ²	23 kg·cm ²	30 kg·cm ²	32 kg·cm ²	39 kg·cm ²	42 kg·cm ²	48 kg·cm ²	51 kg·cm ²
ID								
Motor with ECI 1323 (singleturn)	1361801-01	1361802-01	1361803-01	1361804-01	1361805-01	1361806-01	1361807-01	1361808-01
Motor with EQI 1335 (multiturn)	1361801-11	1361802-11	1361803-11	1361804-11	1361805-11	1361806-11	1361807-11	1361808-11

¹⁾ At 100 K ²⁾ Max. 200 ms

Rotatable connections

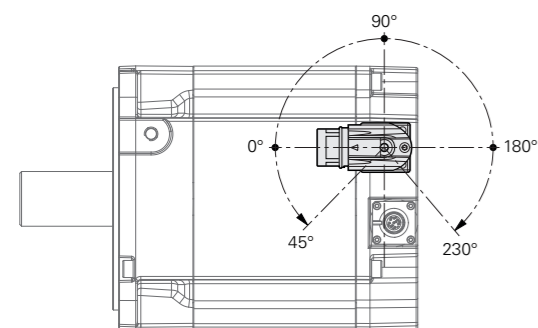

Straight encoder cable

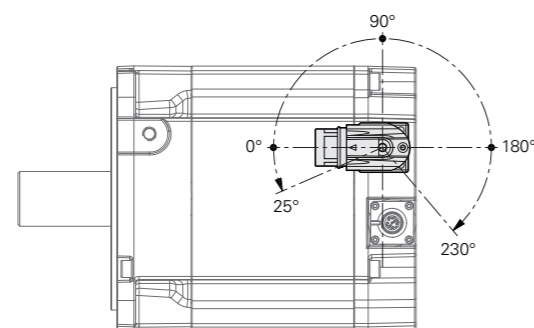

Angled encoder cable (optional)

Encoder connector

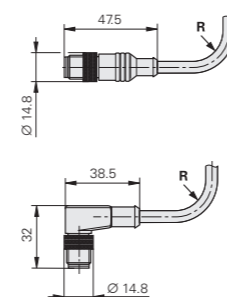

MSY 155 B Without brake

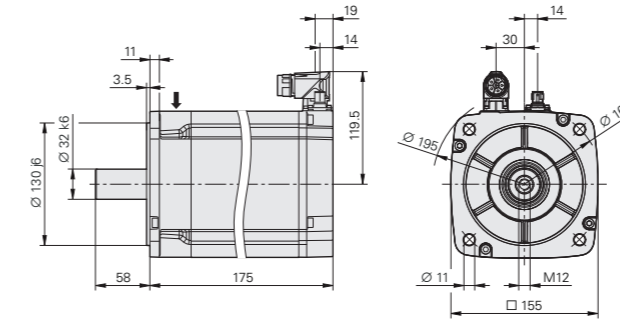

With brake

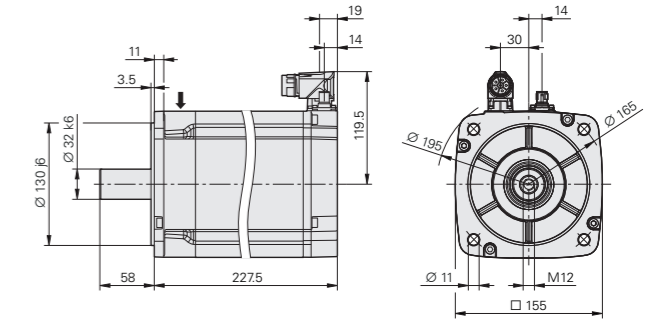

MSY 155 C Without brake

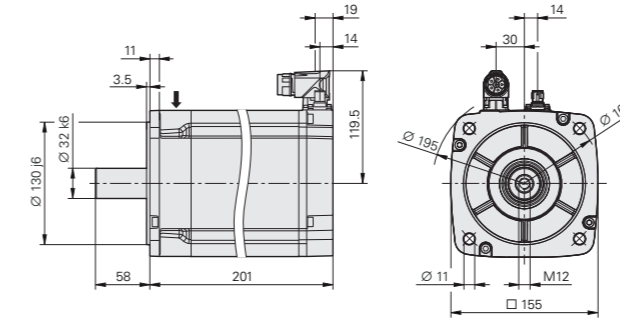

With brake

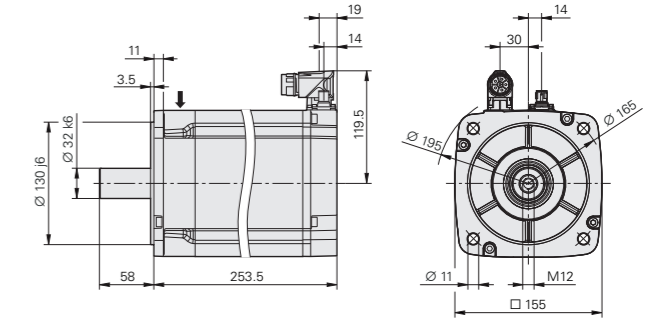

MSY 155 D Without brake

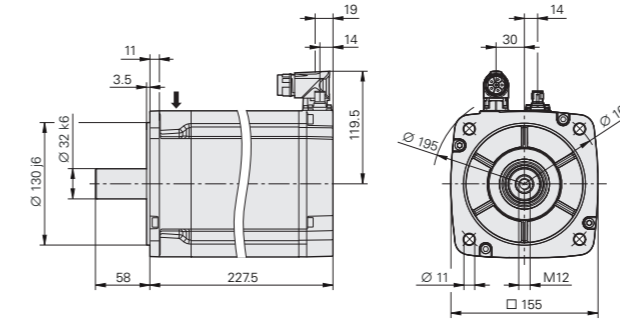

With brake

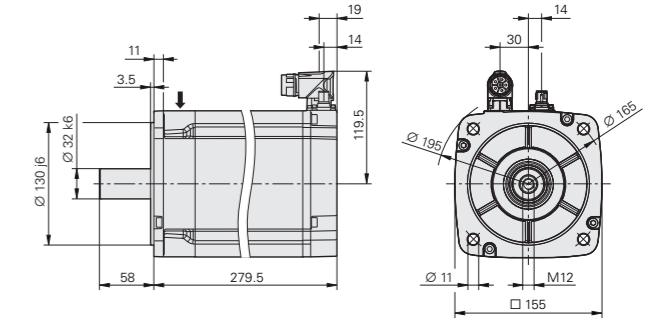

MSY 155 E Without brake

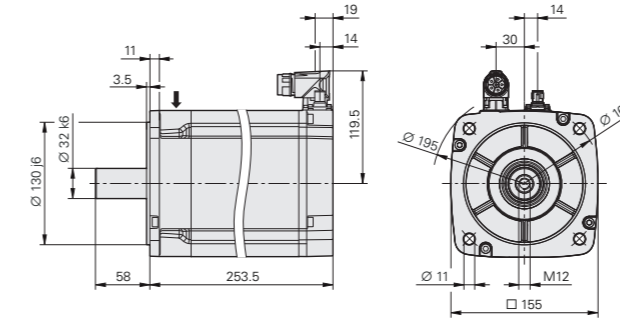

With brake

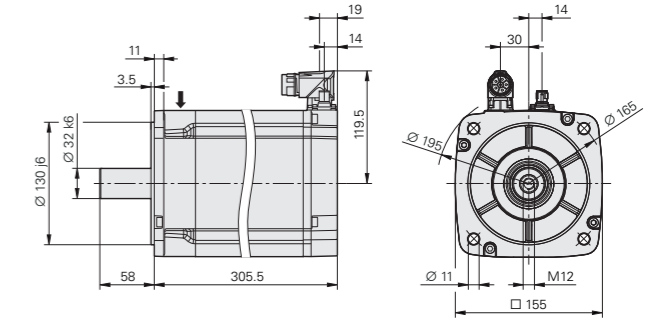

Power connector

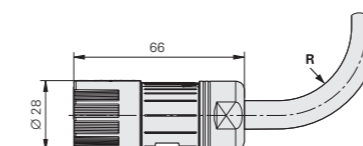

mm
 Tolerancing ISO 8015
 ISO 2768:1989-mH
 ≤ 6 mm: ±0.2 mm

Synchronous motors

MSY 192 series

Feed motors with four pole pairs

- Stall torque: 30.3 Nm to 54.5 Nm
- With HEIDENHAIN inductive absolute rotary encoders (singleturn or multiturn) and the purely serial EnDat 2.2 interface



Motor	MSY 192 C	MSY 192 D	MSY 192 E	MSY 192 F				
Rated voltage U_N	308 V	280 V	293 V	289 V				
Rated power output P_N	5.3 kW	6.5 kW	6.6 kW	7.0 kW				
Rated speed n_N	2000 rpm							
Rated torque $M_N^{1)}$	25.4 Nm	30.9 Nm	31.4 Nm	33.2 Nm				
Rated current $I_N^{1)}$	11.5 A	13.6 A	14.4 A	15.3 A				
Stall torque $M_0^{1)}$	30.3 Nm	39.0 Nm	46.0 Nm	54.5 Nm				
Stall current $I_0^{1)}$	13.2 A	18.3 A	20.1 A	24.0 A				
Maximum speed n_{max}	5000 rpm							
Max. torque $M_{max}^{2)}$	96 Nm	134 Nm	162 Nm	194 Nm				
Max. current $I_{max}^{2)}$	42.7 A	63.8 A	71.1 A	85.4 A				
Brake	Without	With	Without	With	Without	With	Without	With
Rated voltage U_{Br}	-	DC 24 V	-	DC 24 V	-	DC 24 V	-	DC 24 V
Rated current I_{Br}	-	1.36 A	-	1.36 A	-	1.36 A	-	1.36 A
Holding torque M_{Br}	-	42 Nm	-	42 Nm	-	70 Nm	-	70 Nm
Mass m	24 kg	29 kg	29 kg	34 kg	34 kg	42 kg	39 kg	47 kg
Rotor inertia J	82 kg·cm ²	86 kg·cm ²	108 kg·cm ²	112 kg·cm ²	133 kg·cm ²	138 kg·cm ²	159 kg·cm ²	164 kg·cm ²
ID								
Motor with ECI 1323 (singleturn)	1366801-01	1366802-01	1366803-01	1366804-01	1366805-01	1366806-01	1366807-01	1366808-01
Motor with EQI 1335 (multiturn)	1366801-11	1366802-11	1366803-11	1366804-11	1366805-11	1366806-11	1366807-11	1366808-11

¹⁾ At 100 K ²⁾ Max. 200 ms

Rotatable connections

For M23 connector (MSY 192 C, MSY 192 D)

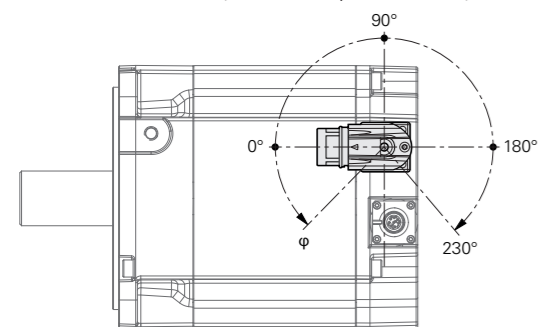

Straight encoder cable ($\varphi = 45^\circ$)
Optional: Angled encoder cable ($\varphi = 25^\circ$)

For M40 connector (MSY 192 E, MSY 192 F)

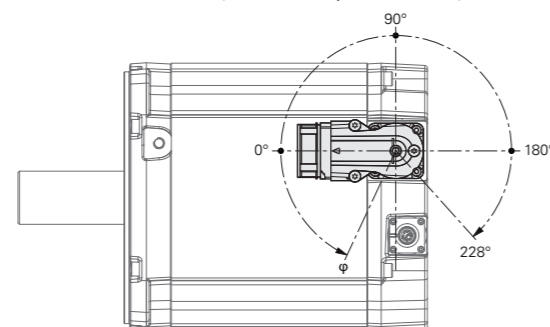

Straight encoder cable ($\varphi = 65^\circ$)
Optional: Angled encoder cable ($\varphi = 30^\circ$)

Encoder connector

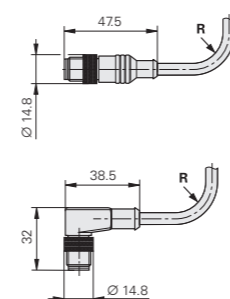

MSY 192 C Without brake

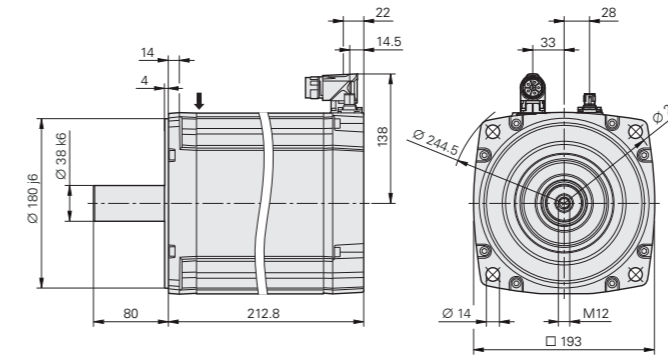

With brake

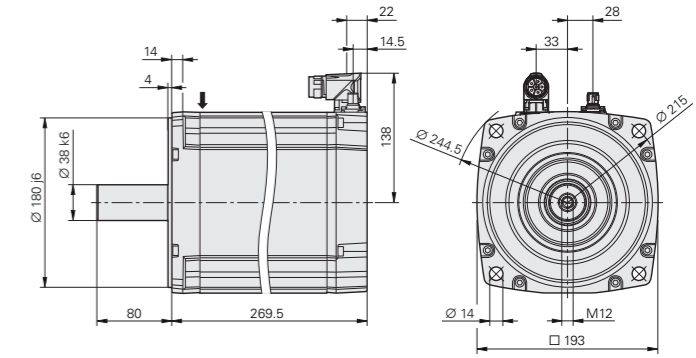

MSY 192 D Without brake

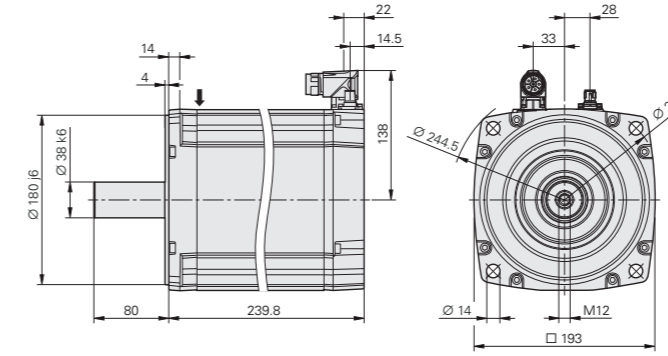

With brake

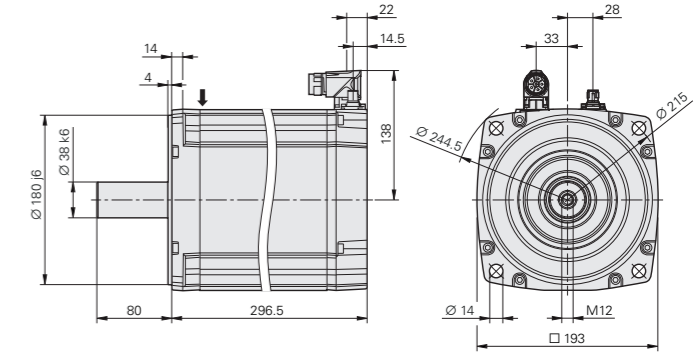

MSY 192 E Without brake

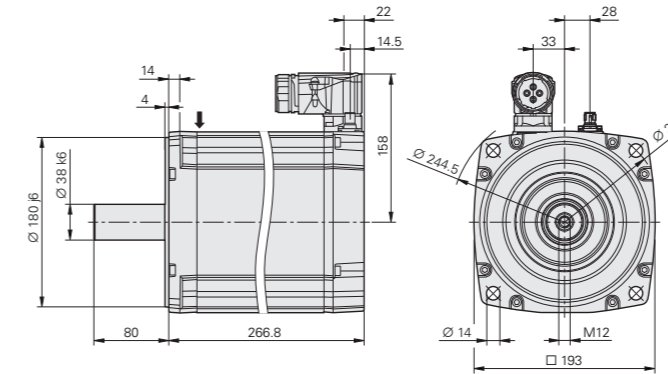

With brake

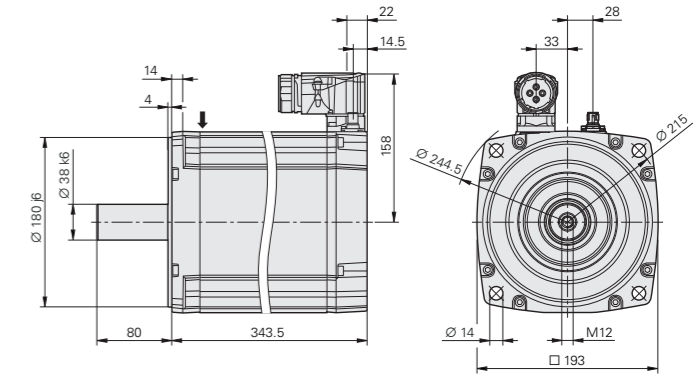

MSY 192 F Without brake

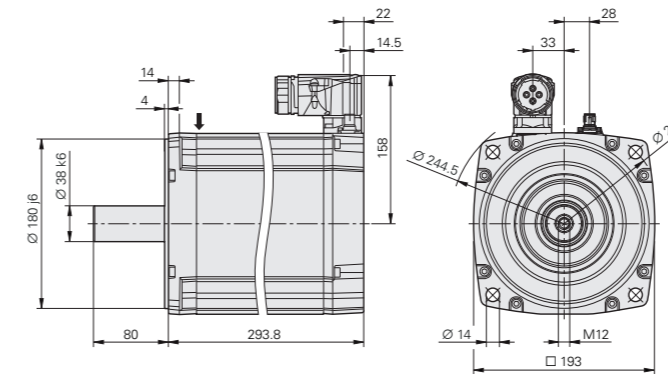

With brake

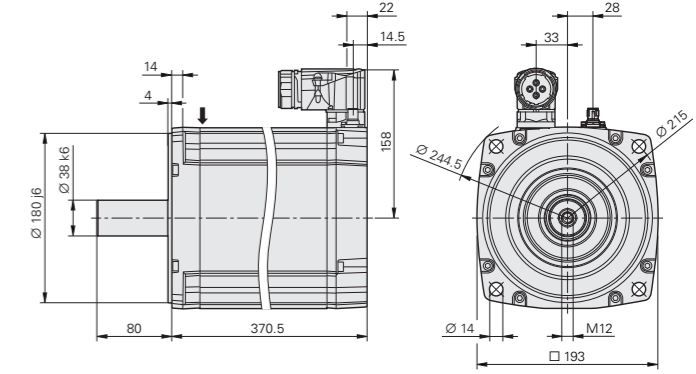

Power connector

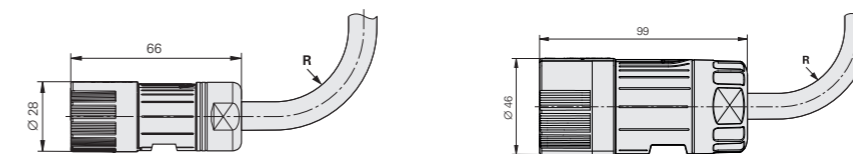

mm
Tolerancing ISO 8015
ISO 2768:1989-mH
≤ 6 mm: ±0.2 mm

Synchronous motors

Torque characteristic curves

--- Characteristic curve according to the specifications (QSY) *) Characteristic curve at maximum motor current (QSY)
 — Measured characteristic curve of one motor (QSY) **) Characteristic curve during the use of compact inverters (QSY)

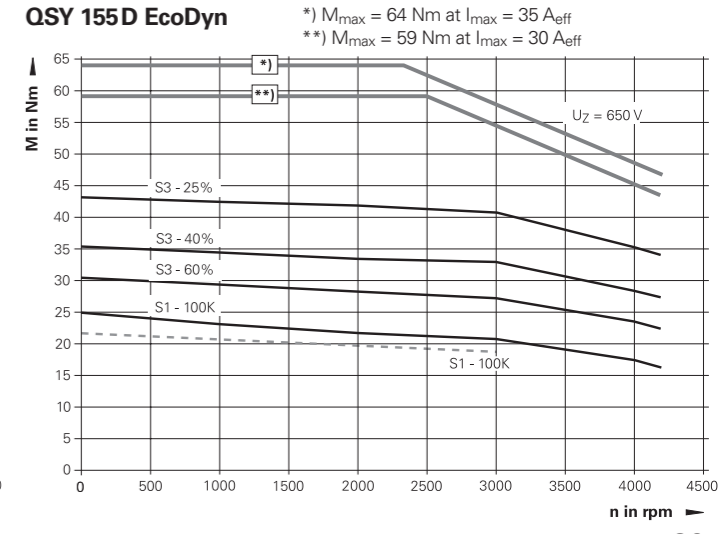
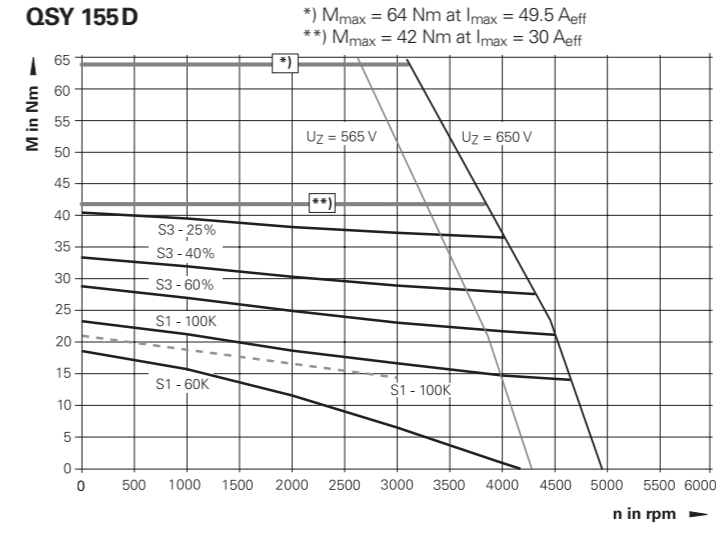
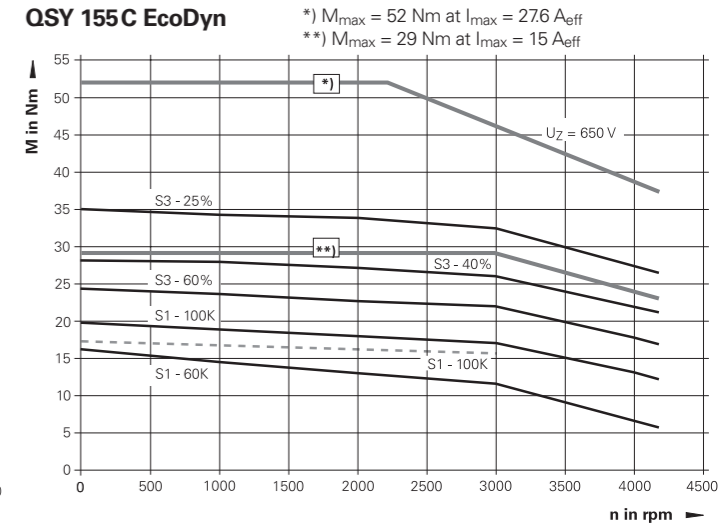
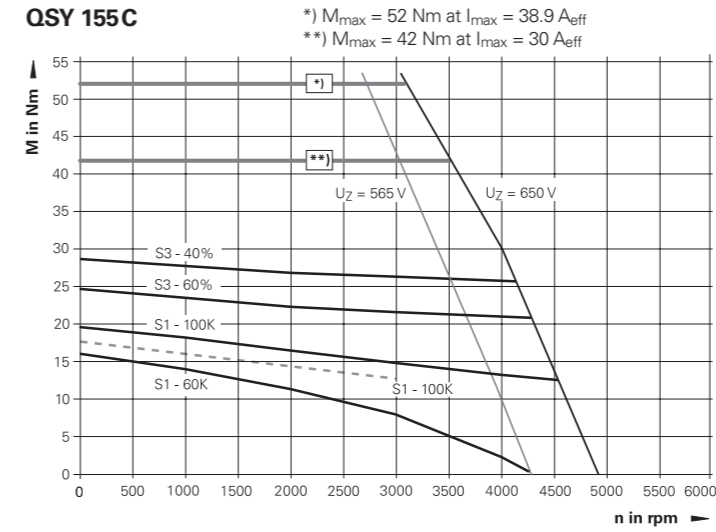
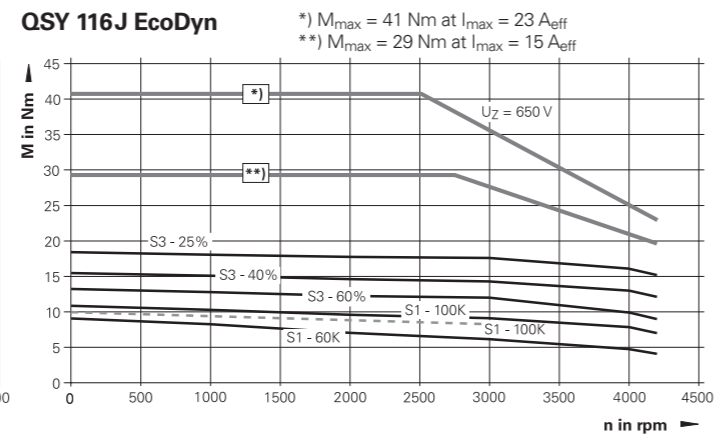
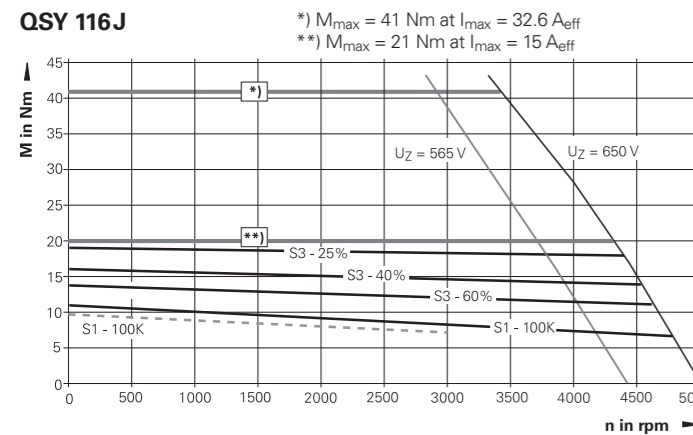
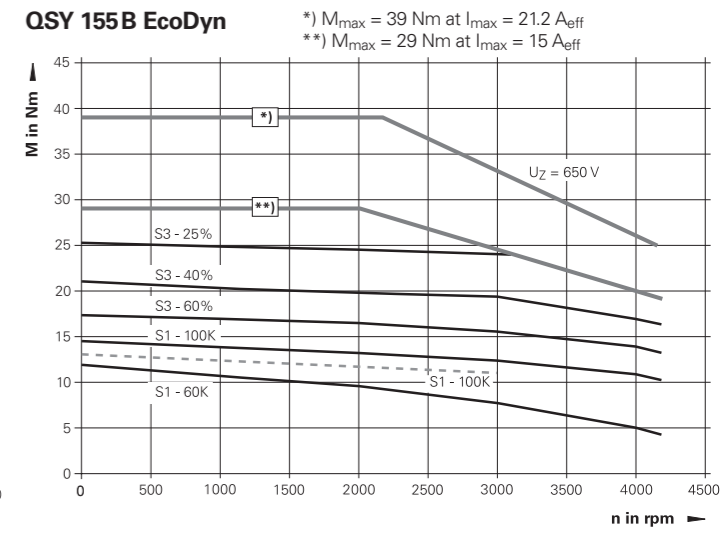
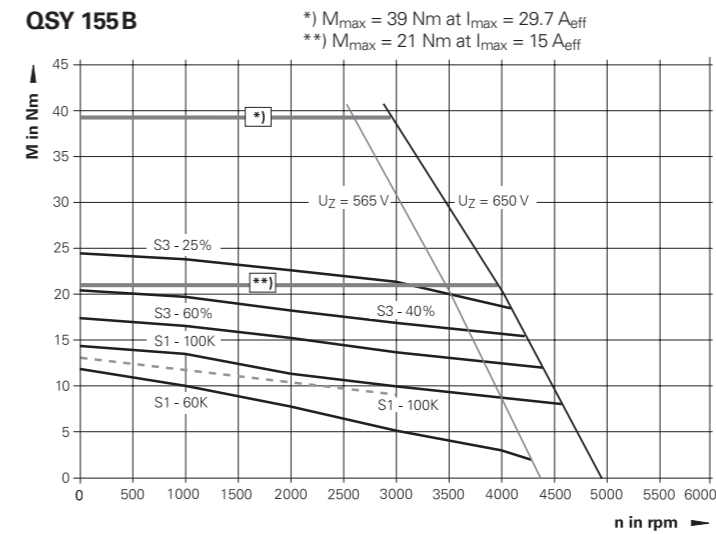
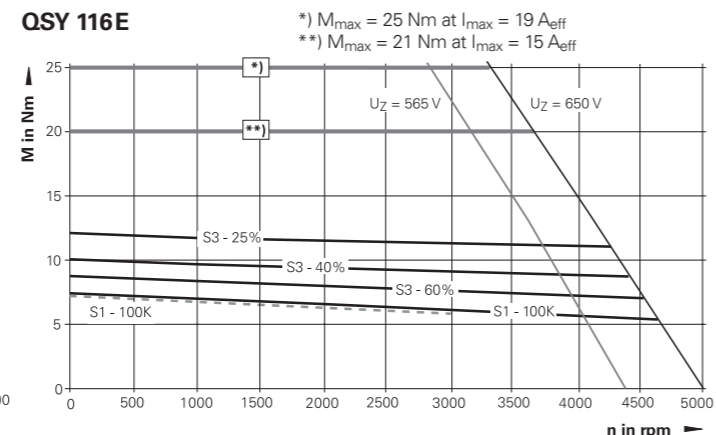
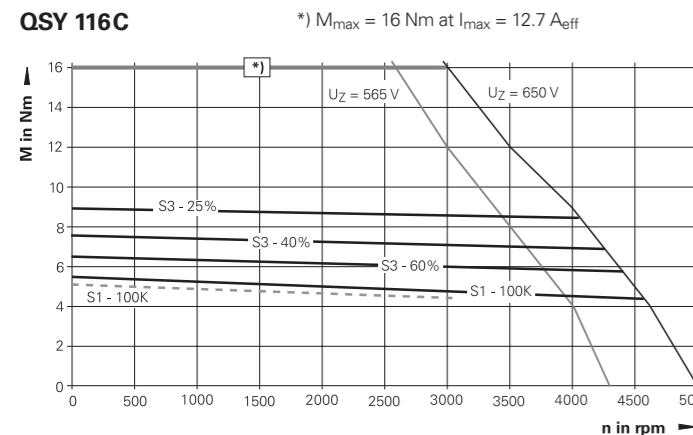
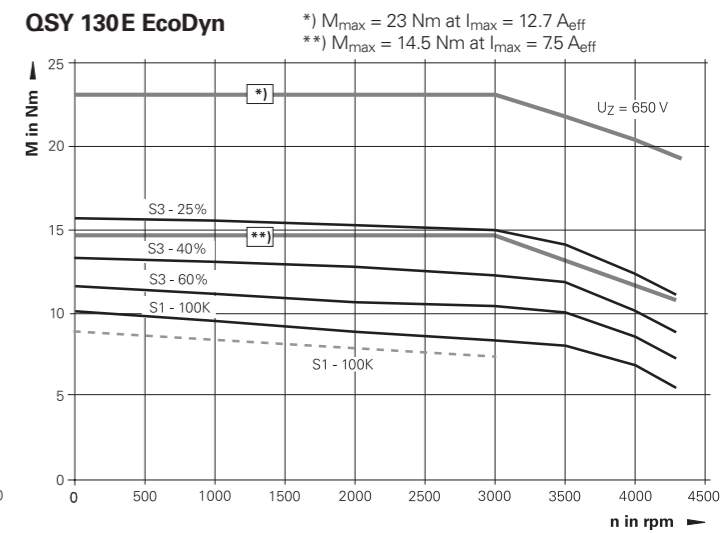
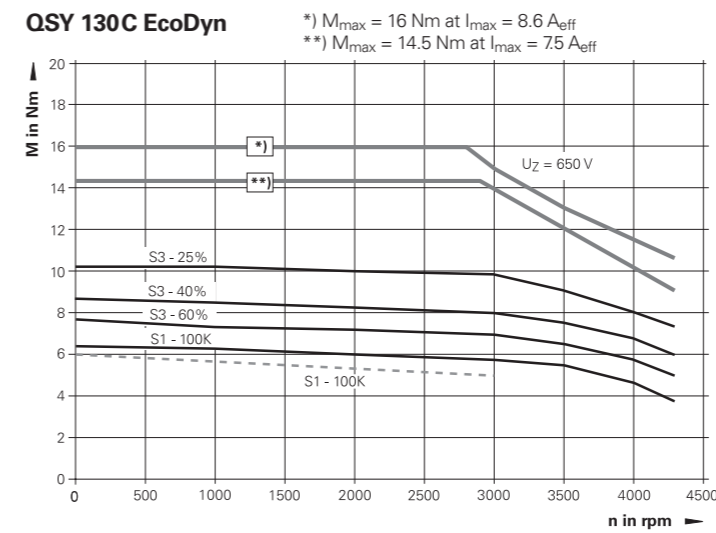
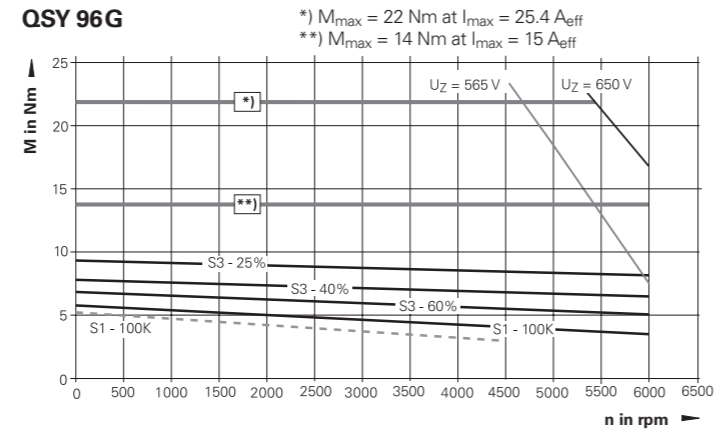
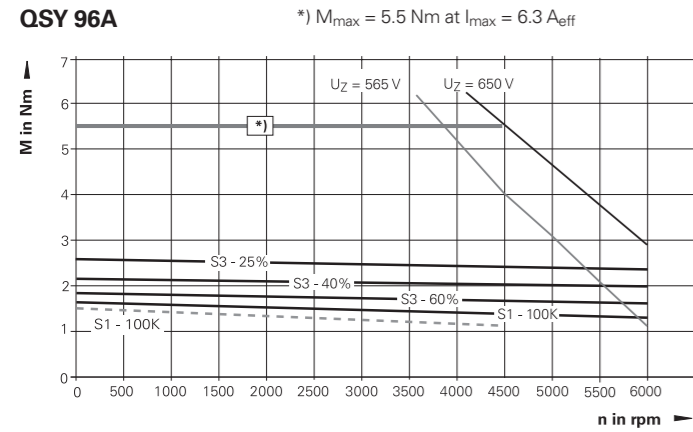

Notes (valid for QSY)

- The characteristic curves apply to motors with the ERN 1387.
- S3 mode
 Cycle duration: 10 minutes
 During the rest period, the motor must be stopped and disconnected from power.

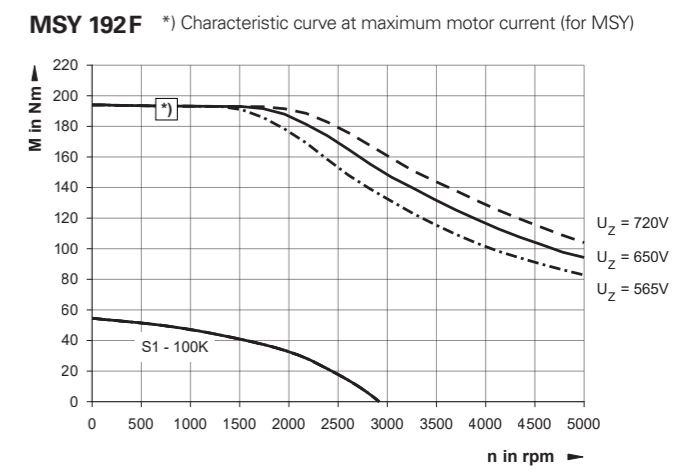
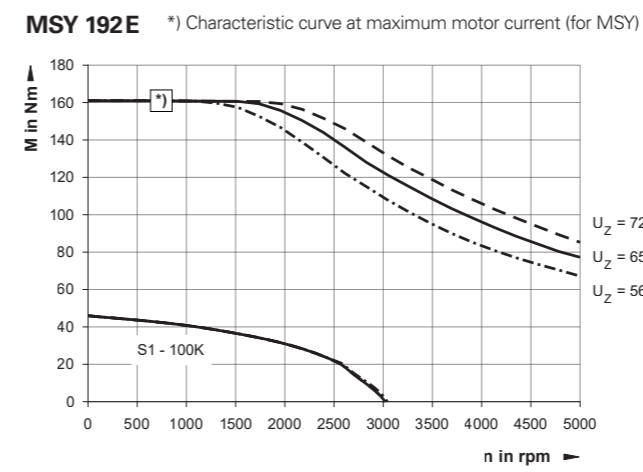
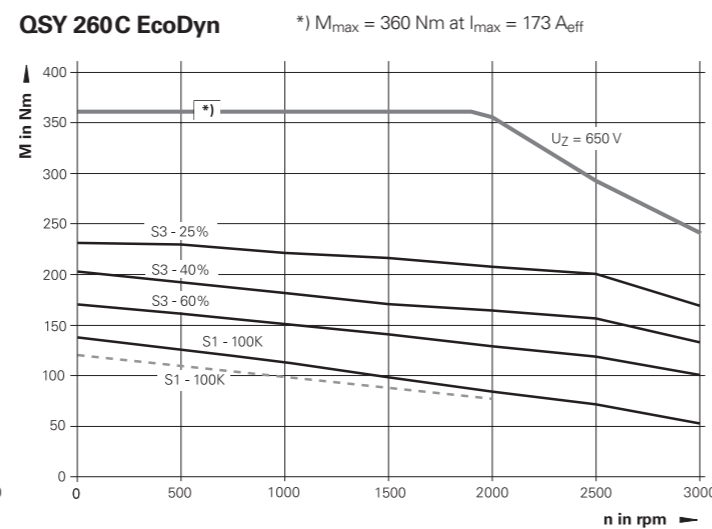
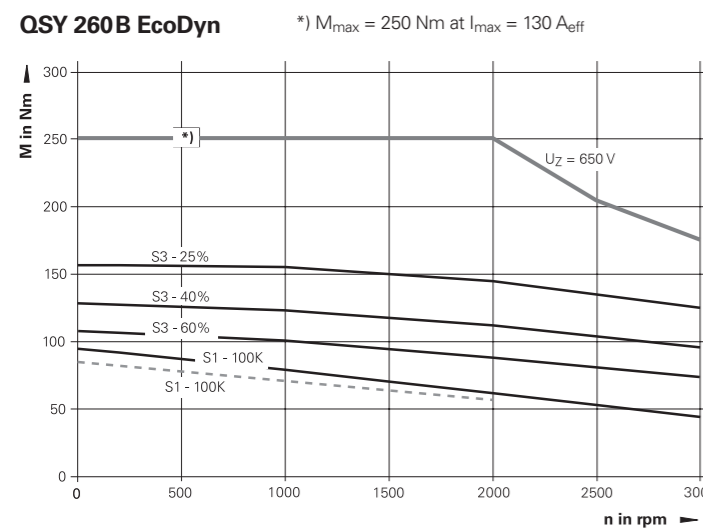
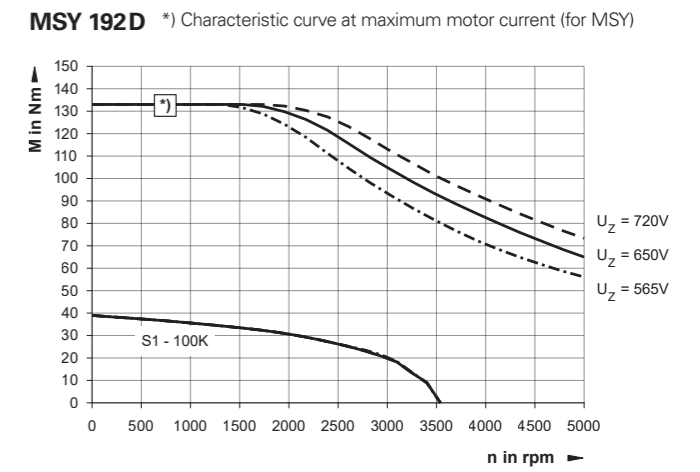
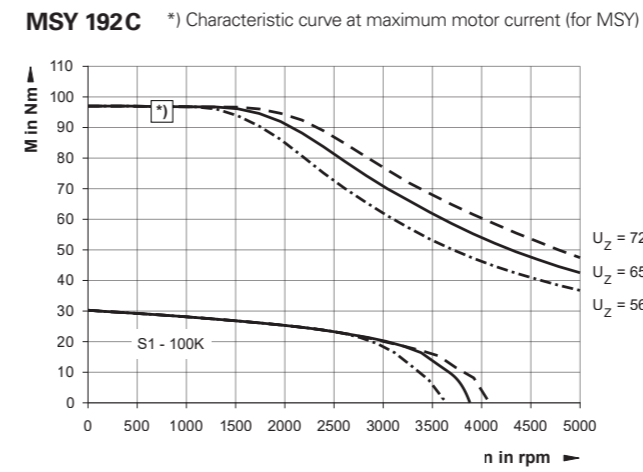
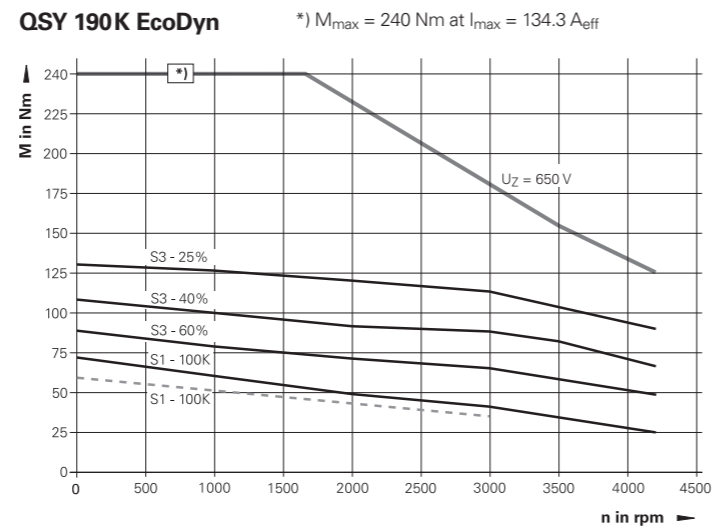
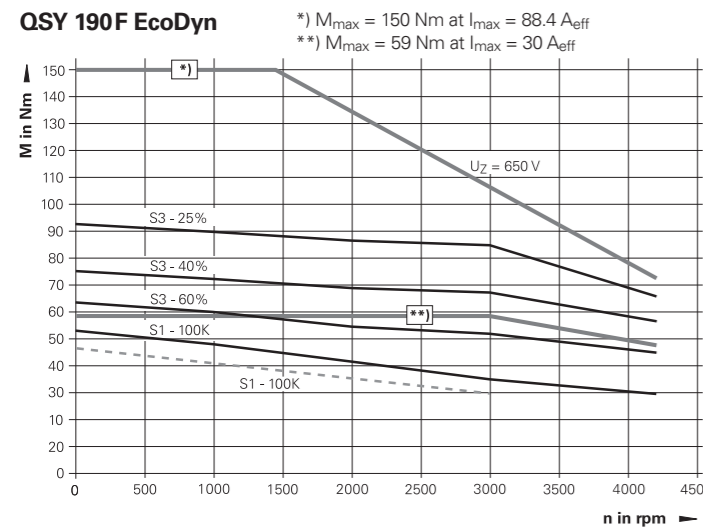
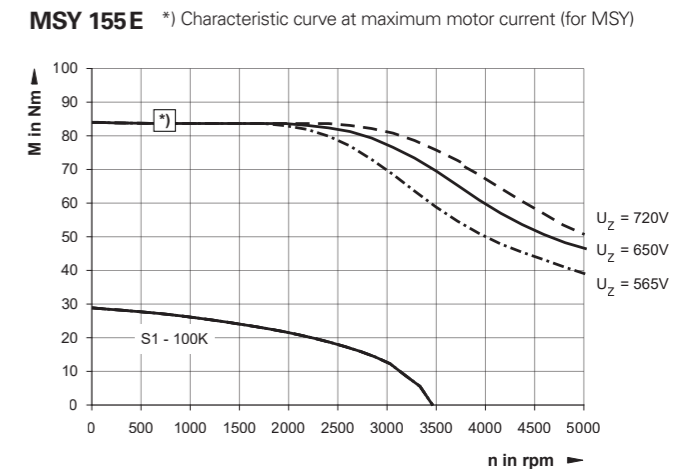
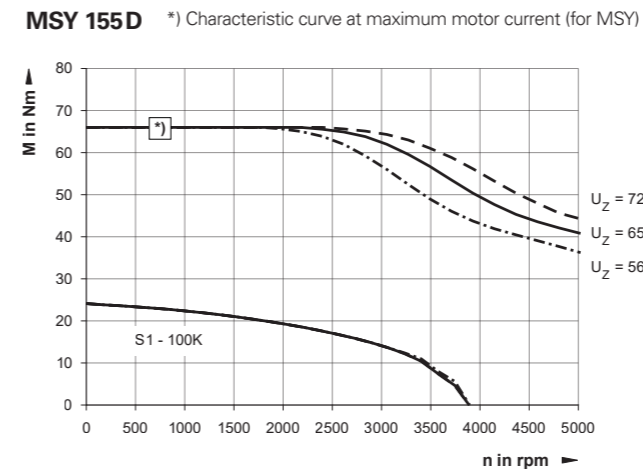
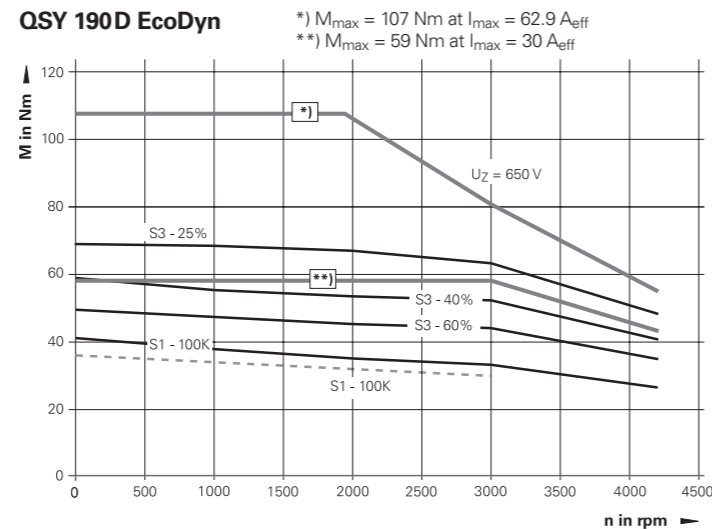
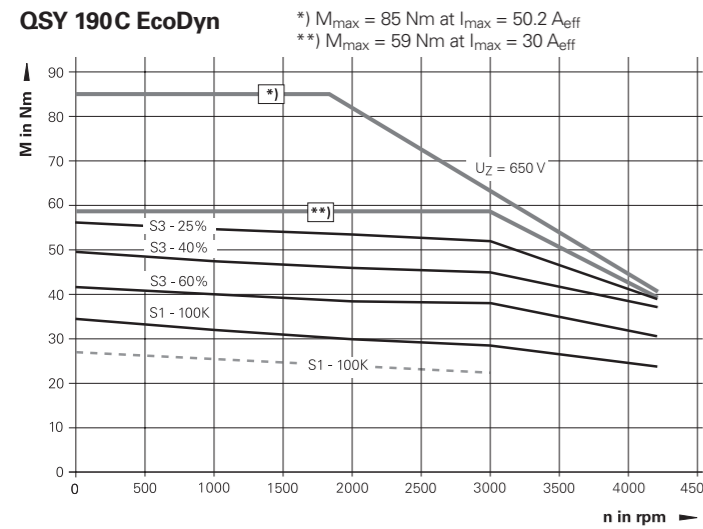
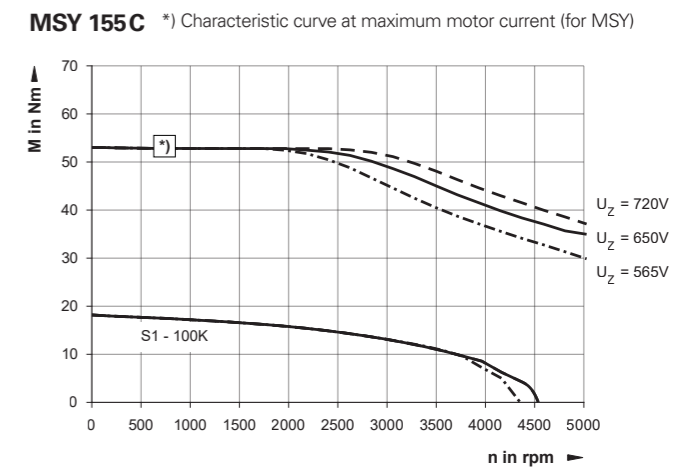
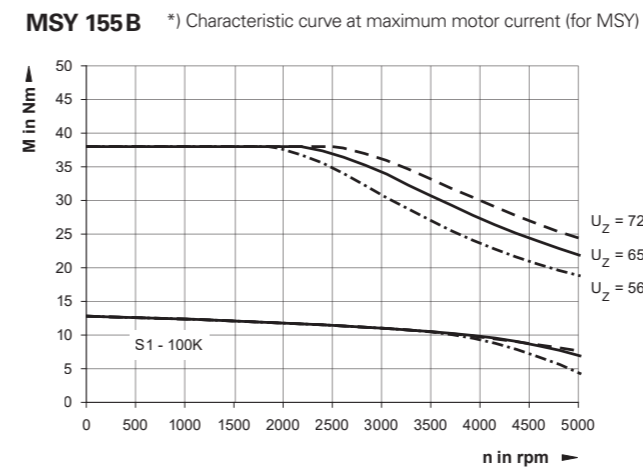
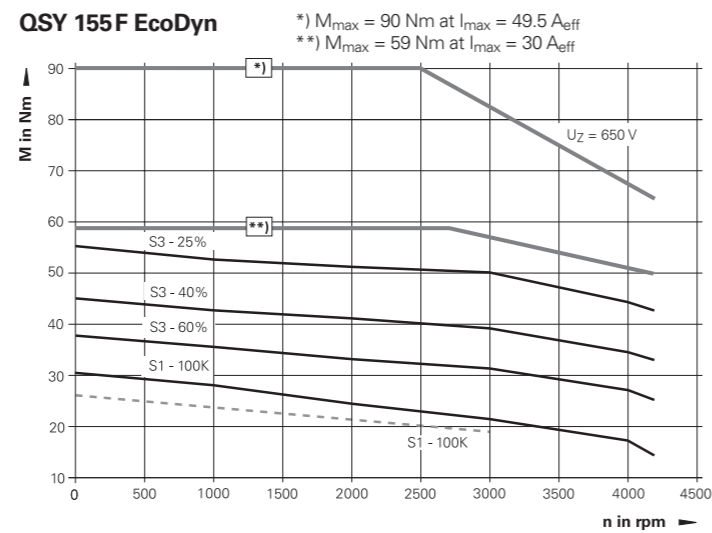
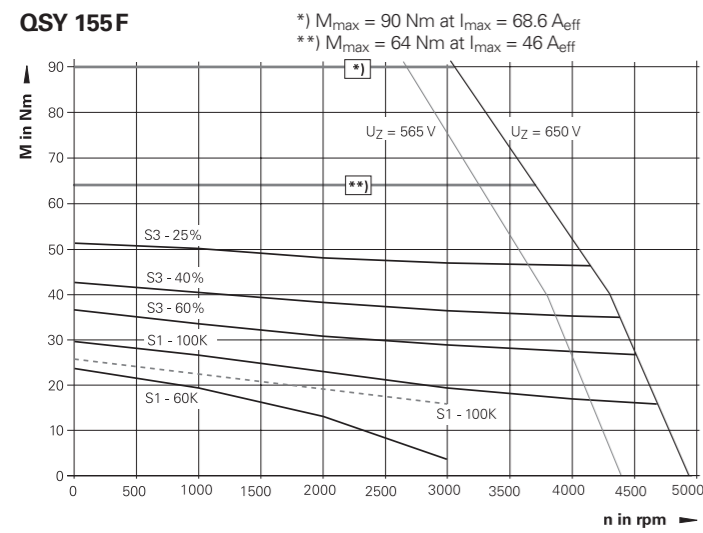

Synchronous motors

Cables and connectors

Power cables

Current load at ambient temperature of up to 40 °C

	Cable with one connector ID	Connector ID	Cable only ID	Bend radius	Cable type	Diameter
Current load of up to 13.8 A						
QSY 96 QSY 116 QSY 130	575796-xx	325165-02	1214270-xx	≥ 105 mm	PUR [4 x 1.5 mm ² + (2 x 1.0 mm ²)]	14.0 mm
QSY 96 (with EnDat 2.2) QSY 116 (with EnDat 2.2) QSY 130 (with EnDat 2.2) QSY 155B EcoDyn QSY 155C EcoDyn QSY 155D EcoDyn MSY 155B MSY 155C	1363300-xx	1290178-04				
QSY 155B QSY 155C QSY 155F EcoDyn	1363327-xx	1361070-03				
Current load of up to 26.0 A						
MSY 155D MSY 155E MSY 192C MSY 192D	1382095-xx	1290178-05	1214271-xx	≥ 119 mm	PUR [4 x 4 mm ² + (2 x 1.0 mm ²)]	15.8 mm
QSY 155D QSY 155F QSY 190C EcoDyn QSY 190D EcoDyn QSY 190F EcoDyn MSY 192E	1363337-xx	1361070-03				
Current load of up to 32.8 A						
QSY 190K EcoDyn QSY 260B EcoDyn (with EnDat 2.2) MSY 192F	1363342-xx	1361070-04	1214272-xx	≥ 130 mm	PUR [4 x 6 mm ² + (2 x 1.0 mm ²)]	17.2 mm
QSY 260B EcoDyn	690141-xx	333090-03				
Current load of up to 45.8 A						
QSY 260C EcoDyn	1214663-xx	333090-03	1213905-xx	≥ 177 mm	PUR [4 x 10 mm ² + (2 x 1.5 mm ²)]	23.5 mm
QSY 260C EcoDyn (with EnDat 2.2)	1363347-xx	1361070-04				

Italics: shielded power cable

Encoder cables

	Cable length	Cable complete with connectors ID	Line drop compensator ID	Extension cable ID	Bend radius R for frequent flexing
QSY 96 QSY 116 QSY 130 QSY 260 (with EQN 1325)	< 60 m	336376-xx	–	340302-xx (as needed)	≥ 100 mm
QSY 155 QSY 190 (with EQN 1325)		1356892-xx		1356400-xx	
QSY 96 QSY 116 QSY 130 QSY 260 (with ERN 1387)	< 30 m	289440-xx	–	336847-xx (as needed)	
QSY 155 QSY 190 (with ERN 1387)		1356866-xx		1355363-xx (as needed)	
QSY 96 QSY 116 QSY 130 QSY 260 (with ERN 1387)	30 m to 60 m	289440-xx	370226-01	336847-xx	
QSY 155 QSY 190 (with ERN 1387)		1356866-xx	370226-02	1355363-xx	
MSY with Exl 13xx and QSY with EQN 1337	< 55 m ¹⁾	1133104-xx (D-sub 25) 1423949-xx (D-sub 25, angled)	–	1036386-xx (angled) 1036372-xx (straight)	≥ 75 mm
	< 100 m	1245639-xx (Mini IO) 1423954-xx (Mini IO, angled)			

¹⁾ < 100 m in conjunction with 1313166-01 and Gen 3

Asynchronous motors

QAN overview

General technical information

Specifications

The specifications and characteristic curves apply to motors mounted without thermal insulation. The maximum permissible temperature divergence from the maximum permissible ambient temperature or coolant temperature of 40 °C is 105 K. If the motor is mounted so that it is thermally insulated, the motor torque must be reduced in order to avoid thermal overloading.

When used in conjunction with Gen 3 drives, motors must be operated only with a DC-link voltage of 650 V.

Shaft bearing

HEIDENHAIN asynchronous motors feature maintenance-free bearings. The shaft bearing on **solid-shaft motors** can be selected as either a standard bearing or a spindle bearing. The version with a spindle bearing can withstand greater radial forces and permits higher spindle speeds. Motors with a spindle bearing exhibit a slightly larger overall length.

The **hollow-shaft motors** are generally equipped with a spindle bearing.

Shaft end

HEIDENHAIN QAN asynchronous motors have a cylindrical shaft end according to DIN EN 50347 and IEC 60072-1. The solid-shaft motors have a centering hole in accordance with DIN 332-DS.

The QAN asynchronous solid-shaft motors can be selected in two shaft versions:

- **Plain shaft end:** This version without a keyway is the standard shaft for all asynchronous motors with a spindle bearing.
- **Shaft end with a keyway:** Asynchronous motors with a keyway are **half-key balanced** and come with a key as per DIN 6885-1:
QAN 200: AS 10 x 8 x 70
QAN 260: AS 12 x 8 x 90
QAN 320: AS 16 x 10 x 90
 The version with a keyway is the standard shaft for all asynchronous motors with a standard bearing.
- **Shaft end with a double keyway:**
QAN 360 UHW: AS 12 x 8 x 96 (2x)

Mechanical service life

The service life of the bearings depends on the shaft load and the average shaft speed. For QAN motors, the nominal bearing service life—which depends on the specific motor and applies for a certain maximum shaft load at an average shaft speed—is 10 000 hours.

Speed measurement

The shaft speed is measured by an integrated HEIDENHAIN rotary encoder:

- ERN 1381 with 1024 lines, for solid-shaft motors
- ERM 2480 with 600 lines, for motors with hollow shaft

Please note:

Until mid-2014, the asynchronous motors delivered with a keyway were **full-key balanced**. The current motors are **half-key balanced**. These motors are uniquely identified by their ID number, which always ends in-xH (e.g., 374328-0H)

Precision balancing

QAN asynchronous motors from HEIDENHAIN can still be balanced at a later time.

Hollow-shaft motors

The QAN 200UH, QAN 260xH and QAN 360UHW hollow-shaft motors are suitable for direct mounting on mechanical spindles. Their hollow shaft permits the conveyance of coolant to internally cooled tools.

The coolant is fed in at the rear of the motor through a rotating union (e.g., from the company Deublin, order no.: 1109-020-188). The shaft end is designed for this.

Installation elevation

HEIDENHAIN motors may be installed at an elevation of up to 1000 m above sea level. For installation at elevations above 1000 m, additional cooling measures are required.

Functional safety

None of the current QAN motor variants described in this brochure feature fault exclusion for the loosening of the mechanical connection between the encoder and the motor. Safety-related parameters for the motors or the encoders used within them are available upon request (e.g., MTTF values, data for fault exclusion).

Thermal parameters

Cooling method:
 QAN 200-320: air-cooled (internal fan)
 QAN 360 UHW: water-cooled
 Temperature monitoring with KTY 84-130 thermistor in the stator winding
 Thermal class F

Mechanical parameters

QAN 200-320 design:
 IM B35 (flange/base mounting) as per EN 60034-7

QAN 360 UHW design:
 IM B5, IM V1

Mounting the motor

The following screws are recommended for mounting the motor:

Mounting type:	Flange	Base
QAN 200	M12	M10
QAN 260	M16	M10
QAN 320	M16	M12
QAN 360 UHW	M10	–

Flange: dimensions as per DIN EN 50347 and IEC 60072-1

Protection as per DIN EN 60529

- Motor: IP54 (QAN 200-320)
 IP43 (QAN 360 UHW)
- Shaft end: IP43

Vibration severity

Grade SR (external precision balancing possible)
 (IEC 60034-14)

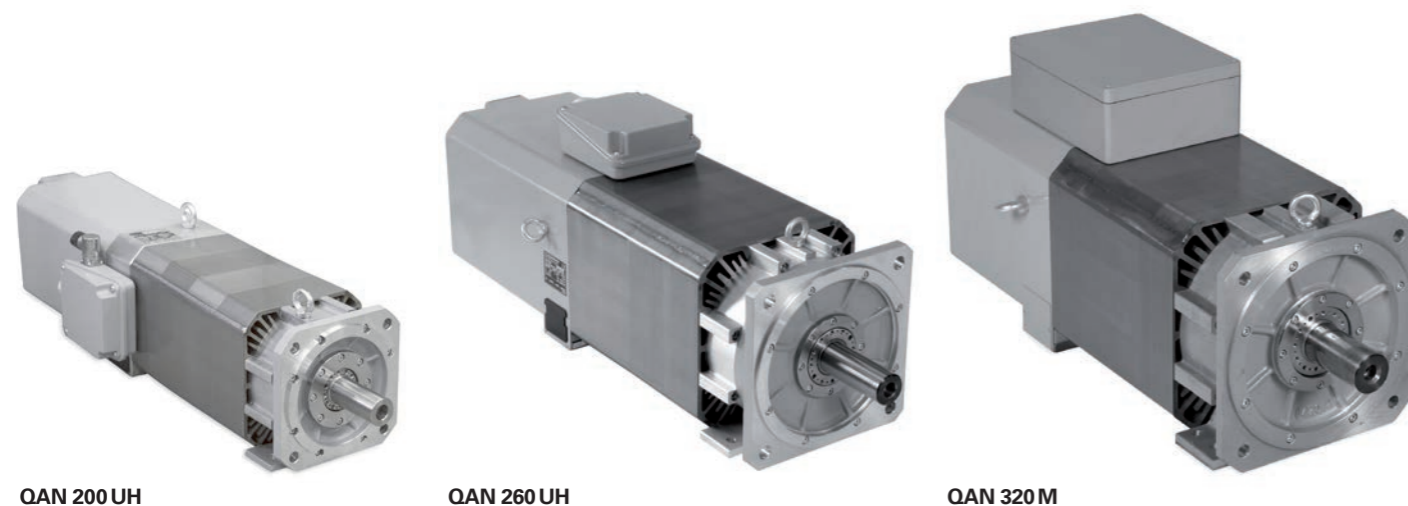

Asynchronous motors When used with 1xx inverter systems

Asynchronous motors with solid shaft	Rated power	Rated speed	Maximum speed		Rated torque	Rated current	Recommended inverters ³⁾			Page
			Standard bearing	Spindle bearing			1-axis module	2-axis module	Compact inverter	
QAN 200M	5.5 kW	1500 rpm	9000 rpm	12 000 rpm	35.0 Nm	18.0 A	UM 112 D	UM 122 D	Spindle output	38
QAN 200L	7.5 kW	1500 rpm	9000 rpm	12 000 rpm	47.8 Nm	20.1 A	UM 112 D	UM 122 D	Spindle output	
QAN 200U	10.0 kW	1500 rpm	9000 rpm	12 000 rpm	63.7 Nm	25.0 A	UM 112 D	UM 122 D	Spindle output ¹⁾	
QAN 260M	15.0 kW	1500 rpm	8000 rpm	10 000 rpm	95.5 Nm	35.0 A	UM 113 D	–	Spindle output ²⁾	40
QAN 260L	20.0 kW	1500 rpm	8000 rpm	10 000 rpm	127.3 Nm	46.0 A	UM 113 D	–	–	
QAN 260U	24.0 kW	1500 rpm	8000 rpm	10 000 rpm	152.8 Nm	58.0 A	UM 114 D	–	–	
QAN 320M	32.0 kW	1500 rpm	8000 rpm	10 000 rpm	203.7 Nm	77.5 A	UM 114 D	–	–	42
QAN 320L	40.0 kW	1500 rpm	8000 rpm	10 000 rpm	254.6 Nm	99.0 A	UM 115 D	–	–	

Asynchronous motors with hollow shaft	Rated power	Rated speed	Maximum speed		Rated torque	Rated current	Recommended inverters ³⁾			Page
			Standard bearing	Spindle bearing			1-axis module	2-axis module	Compact inverter	
QAN 200UH	10.0 kW	1500 rpm	–	12 000 rpm 15 000 rpm	63.7 Nm	25.0 A	UM 112 D	UM 122 D	Spindle output ¹⁾	44
QAN 260MH	15.0 kW	1500 rpm	–	12 000 rpm	96.0 Nm	35.0 A	UM 113 D	–	Spindle output ²⁾	46
QAN 260LH	20.0 kW	1500 rpm	–	12 000 rpm	128.0 Nm	46.0 A	UM 113 D	–	–	
QAN 260UH	22.0 kW	1500 rpm	–	10 000 rpm 12 000 rpm	140.0 Nm	54.0 A	UM 113D ¹⁾ UM 114 D	–	–	
QAN 360UHW	43.2 kW	Wye connection: 450 rpm Delta connection: 780 rpm	–	7000 rpm	Wye connection: 917 Nm Delta connection: 529 Nm	Wye connection: 113 A Delta connection: 124 A	UM 115 D	–	–	48

¹⁾ Only UE 24xB, UR 24x

²⁾ Only UR 24x

³⁾ The maximum acceleration of the motor might not be achievable with the recommended inverters. If necessary, a more powerful power module must be selected.

When used with Gen 3 drives

Asynchronous motors with solid shaft	Rated power	Rated speed	Maximum speed		Rated torque	Rated current	Recommended inverters ¹⁾					Page
			Standard bearing	Spindle bearing			1-axis module	2-axis module	Compact inverters/axis			
									UEC 31x	UEC 32x	UEC 33x	
QAN 200M	5.5 kW	1500 rpm	9000 rpm	12 000 rpm	35.0 Nm	18.0 A	UM 311	UM 321	1 to 2	1 to 2	1 to 5	38
QAN 200L	7.5 kW	1500 rpm	9000 rpm	12 000 rpm	47.8 Nm	20.1 A	UM 311	UM 321	1 to 2	1 to 2	1 to 5	
QAN 200U	10.0 kW	1500 rpm	9000 rpm	12 000 rpm	63.7 Nm	25.0 A	UM 312	UM 322	–	1 to 2	1 to 2	
QAN 260M	15.0 kW	1500 rpm	8000 rpm	10 000 rpm	95.5 Nm	35.0 A	UM 312	UM 322	–	–	1 to 2	40
QAN 260L	20.0 kW	1500 rpm	8000 rpm	10 000 rpm	127.3 Nm	46.0 A	UM 313	–	–	–	1	
QAN 260U	24.0 kW	1500 rpm	8000 rpm	10 000 rpm	152.8 Nm	58.0 A	UM 313	–	–	–	–	
QAN 320M	32.0 kW	1500 rpm	8000 rpm	10 000 rpm	203.7 Nm	77.5 A	UM 314	–	–	–	–	42
QAN 320L	40.0 kW	1500 rpm	8000 rpm	10 000 rpm	254.6 Nm	99.0 A	UM 315	–	–	–	–	

Asynchronous motors with hollow shaft	Rated power	Rated speed	Maximum speed		Rated torque	Rated current	Recommended inverters ¹⁾		Page
			Standard bearing	Spindle bearing			1-axis module	2-axis module	
QAN 200UH	10.0 kW	1500 rpm	–	12 000 rpm 15 000 rpm	63.7 Nm	25.0 A	UM 312	UM 322	44
QAN 260MH	15.0 kW	1500 rpm	–	12 000 rpm	96.0 Nm	35.0 A	UM 312	UM 322	46
QAN 260LH	20.0 kW	1500 rpm	–	12 000 rpm	128.0 Nm	46.0 A	UM 313	–	
QAN 260UH	22.0 kW	1500 rpm	–	10 000 rpm 12 000 rpm	140.0 Nm	54.0 A	UM 313 UM 313	–	
QAN 360UHW	43.2 kW	Wye connection: 450 rpm Delta connection: 780 rpm	–	7000 rpm	Wye connection: 917 Nm Delta connection: 529 Nm	Wye connection: 113 A Delta connection: 124 A	UM 315	–	48

¹⁾ The maximum acceleration of the motor might not be achievable with the recommended inverters. If necessary, a more powerful power module must be selected.

Asynchronous motors with solid shaft

QAN 200 series

- Spindle motors with two pole pairs
- Rated power output: 5.5 kW to 10 kW
- Choice of standard or spindle bearing

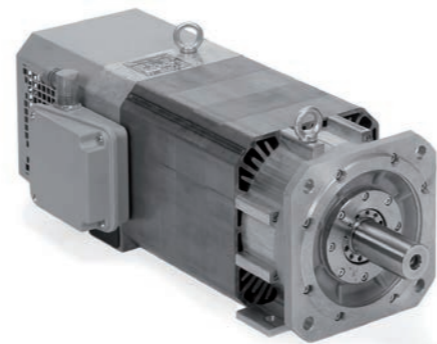

Motor	QAN 200M	QAN 200L	QAN 200U			
Rated voltage U_N	250 V	305 V	330 V			
Rated power output P_N	5.5 kW	7.5 kW	10.0 kW			
Rated speed n_N	1500 rpm					
Rated torque M_N (105 K)	35.0 Nm	47.8 Nm	63.7 Nm			
Rated current I_N (105 K)	18.0 A	20.1 A	25.0 A			
Efficiency	0.85					
Maximum speed n_{max} ¹⁾						
Standard bearing	9000 rpm	9000 rpm				
Spindle bearing	12000 rpm	12000 rpm				
Max. current I_{max}	33 A	36 A	44 A			
Mass m	51 kg	68 kg	83 kg			
Rotor inertia J	245 kg·cm ²	353 kg·cm ²	405 kg·cm ²			
Protection	IP54					
Fan						
Rated voltage U_L	3AC 400 V					
Rated current I_L	0.17 A/0.2 A					
Frequency f_L	50 Hz/60 Hz					
ID						
Motor with standard bearing	Plain shaft 374328-03	With keyway 374328-0H 374328-1H	Plain shaft 374329-03	With keyway 374329-0H 374329-1H	Plain shaft 374330-03	With keyway 374330-0H 374330-1H
Motor with spindle bearing	374328-13		374329-13		374330-13	

¹⁾The maximum shaft speed depends on the application conditions of the motor, such as the shaft load (see the *Motors Technical Manual*)

Bold: standard version

Rotatable connections

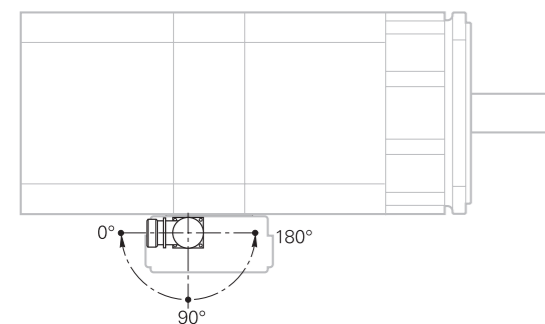

Encoder connector

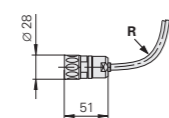

For **R** see page 56

QAN 200M

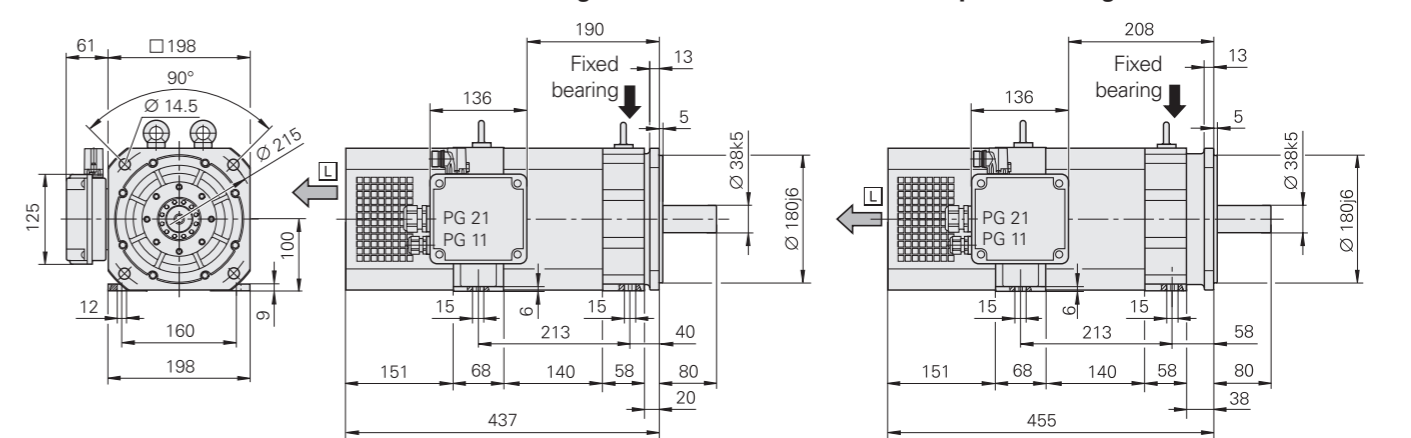

QAN 200L

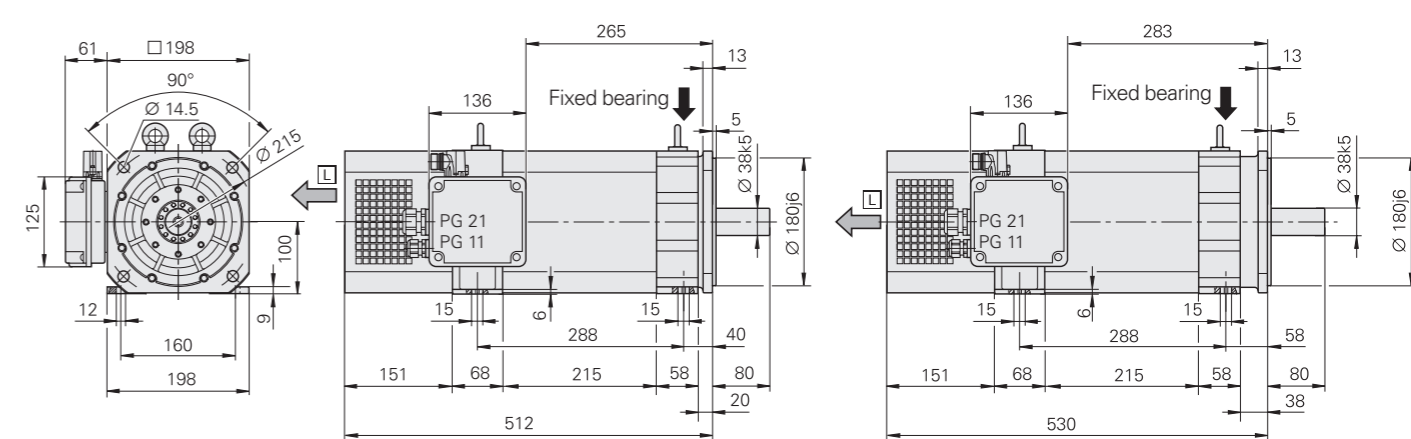

QAN 200U

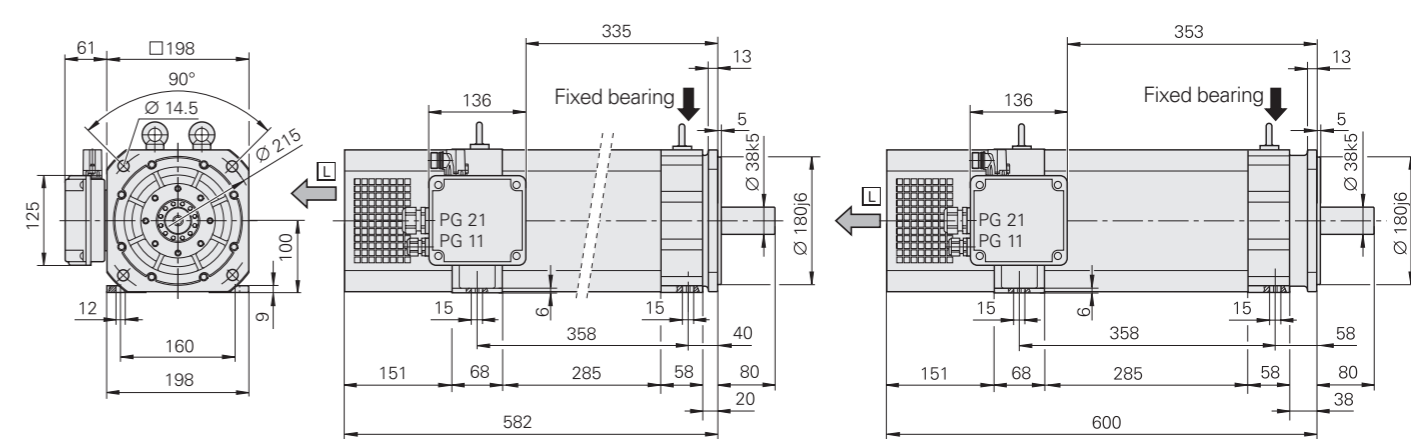

□ = Air flow
PG 11: 5 mm to 10 mm
PG 21: 13 mm to 18 mm

mm
Tolerancing ISO 8015
ISO 2768:1989-mH
≤ 6 mm: ±0.2 mm

Asynchronous motors with solid shaft

QAN 260 series

- Spindle motors with two pole pairs
- Rated power output: 12 kW to 24 kW
- Choice of standard or spindle bearing

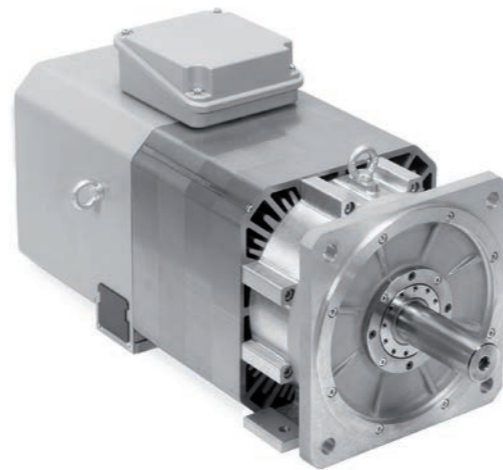

Motor	QAN 260M	QAN 260L	QAN 260U			
Rated voltage U_N	348 V	331 V	318 V			
Rated power output P_N	15 kW	20 kW	24 kW			
Rated speed n_N	1500 rpm					
Rated torque M_N (105 K)	96 Nm	128 Nm	153 Nm			
Rated current I_N (105 K)	35 A	46 A	58 A			
Efficiency	0.85					
Maximum speed n_{max} ¹⁾	Standard bearing 10000 rpm Spindle bearing* 12000 rpm		8000 rpm 10000 rpm			
Max. current I_{max}	70 A	96 A	116 A			
Mass m	112 kg	135 kg	158 kg			
Rotor inertia J	700 kg·cm ²	920 kg·cm ²	1100 kg·cm ²			
Protection	IP54					
Fan	Rated voltage U_L 3AC 400 V Rated current I_L 0.22 A/0.26 A Frequency f_L 50 Hz/60 Hz					
ID	Solid shaft 510019-63	With keyway 510019-4H	Solid shaft 510020-43	With keyway 510020-4H	Solid shaft 510021-43	With keyway 510021-4H
	10000 rpm 510019-53 12000 rpm 510019-73	510019-5H -	510020-53 510020-73	510020-5H -	510021-53 -	510021-5H -

¹⁾ The maximum shaft speed depends on the application conditions of the motor, such as the shaft load (see the *Motors Technical Manual*)

* Please select when ordering

Bold: standard version

Rotatable connections

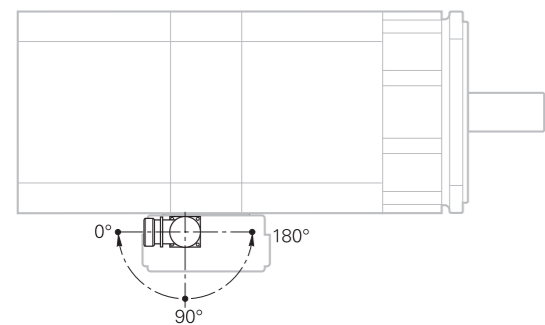

Encoder connector

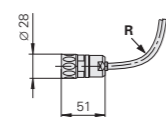

For **R** see page 56

QAN 260M

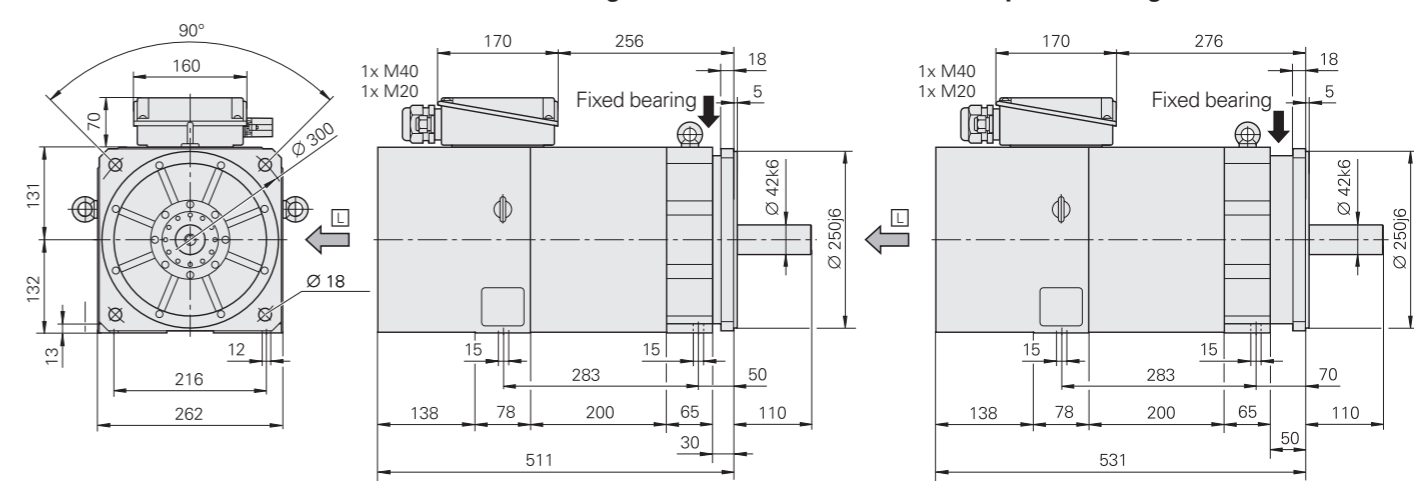

QAN 260L

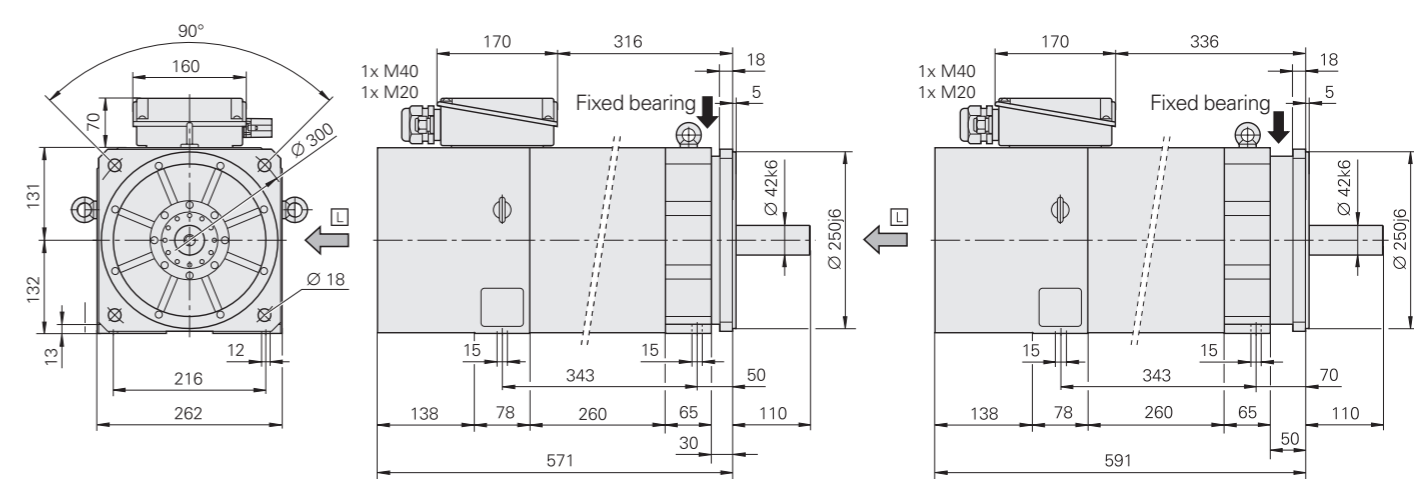

QAN 260U

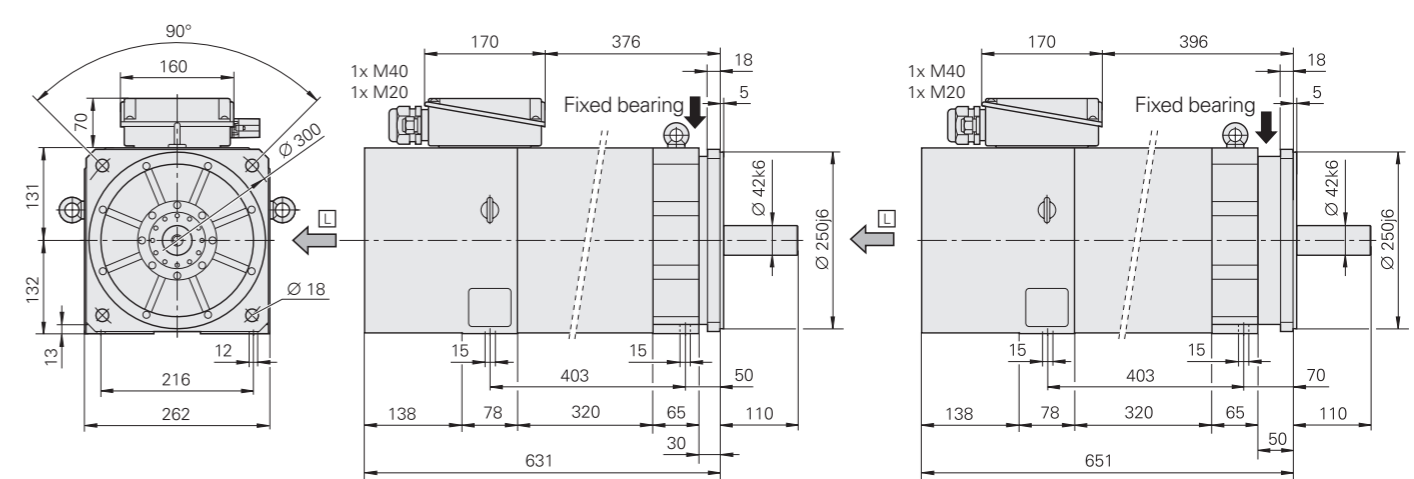

☐ = Air flow

QAN 260M

M20: 6 mm to 12 mm
M40: 20 mm to 26 mm

QAN 260L/U

M20: 6 mm to 12 mm
M40: 22 mm to 32 mm

mm
Tolerancing ISO 8015
ISO 2768:1989-mH
≤ 6 mm: ±0.2 mm

Asynchronous motors with solid shaft

QAN 320 series

Spindle motors with two pole pairs
 • Rated power output: 18 kW to 40 kW

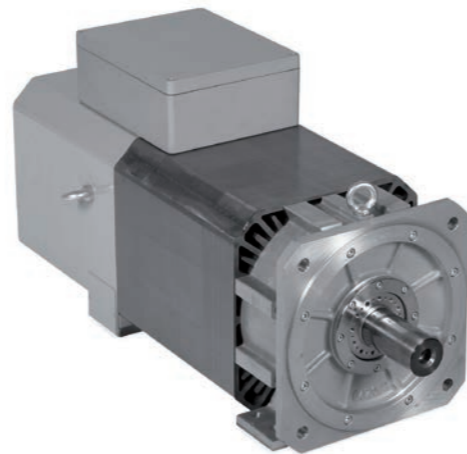

Motor	QAN 320M	QAN 320L
Rated voltage U_N	317 V	315 V
Rated power output P_N	32 kW	40 kW
Rated speed n_N	1500 rpm	1500 rpm
Rated torque M_N (105 K)	203.7 Nm	254.6 Nm
Rated current I_N (105 K)	77.5 A	99.0 A
Efficiency	0.85	0.91
Maximum speed n_{max}¹⁾ Standard bearing Spindle bearing	8000 rpm 10000 rpm	
Max. current I_{max}	155 A	186 A
Mass m	240 kg	280 kg
Rotor inertia J	1870 kg·cm ²	2300 kg·cm ²
Fan Rated voltage U_L Rated current I_L Frequency f_L	3AC 400 V 0.38 A/0.48 A 50 Hz/60 Hz	
ID Motor with standard bearing Motor with spindle bearing	Plain shaft 513302-43 513302-53	With keyway 513302-4H 513302-5H
		Plain shaft 577484-43 577484-53
		With keyway 577484-4H 577484-5H

¹⁾The maximum shaft speed depends on the application conditions of the motor, such as the shaft load (see the *Motors Technical Manual*)

Bold: standard version

QAN 320M

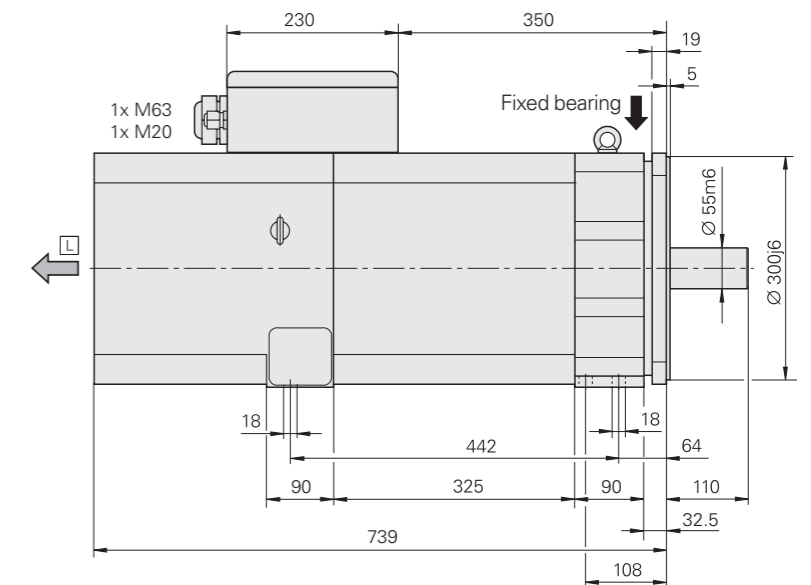
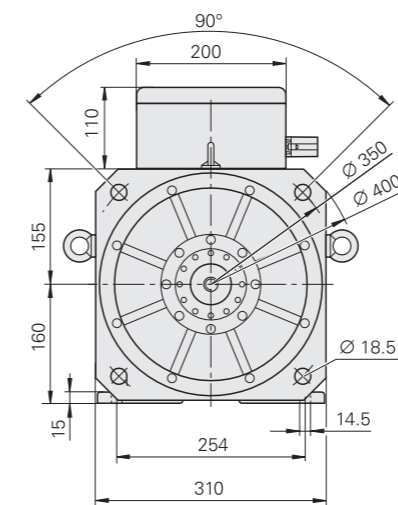

QAN 320L

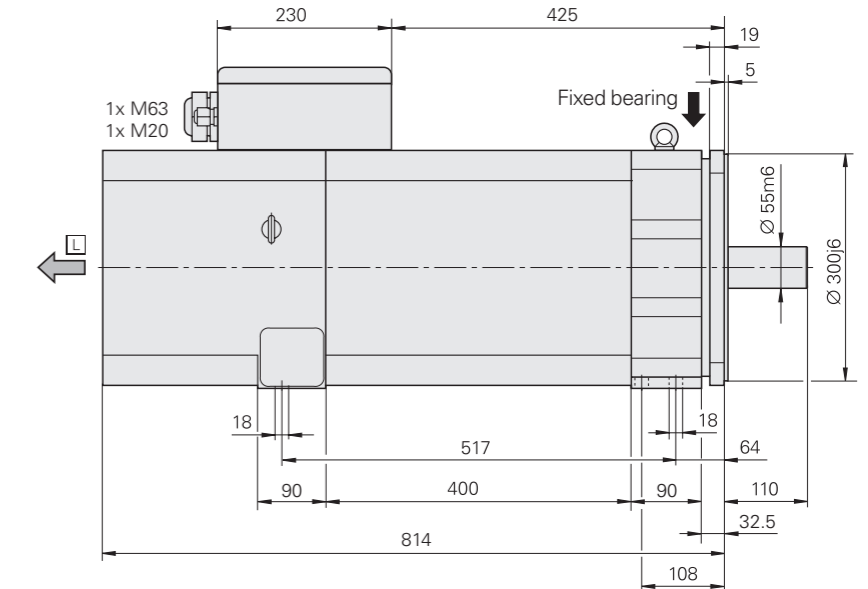
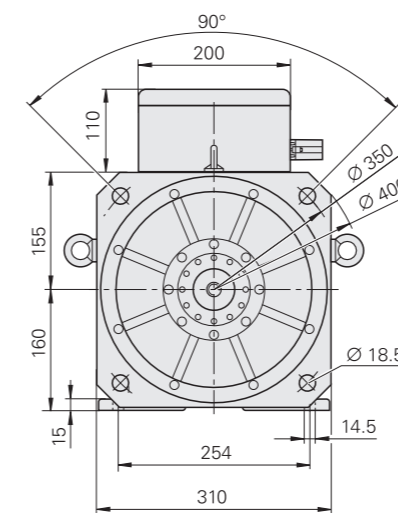

Rotatable connections

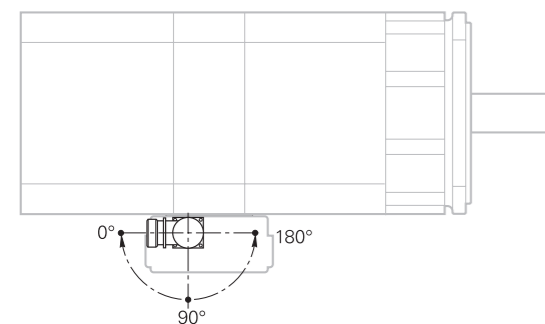

Encoder connector

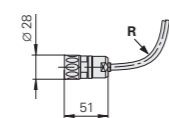

For **R** see page 56

☐ = Air flow
 M20: 6 mm to 12 mm
 M63: 34 mm to 45 mm

mm

 Tolerancing ISO 8015
 ISO 2768:1989-mH
 ≤ 6 mm: ±0.2 mm

Asynchronous motors with hollow shaft

QAN 200UH

Hollow-shaft spindle motor with two pole pairs

- Rated power output: up to 10 kW
- With spindle bearing

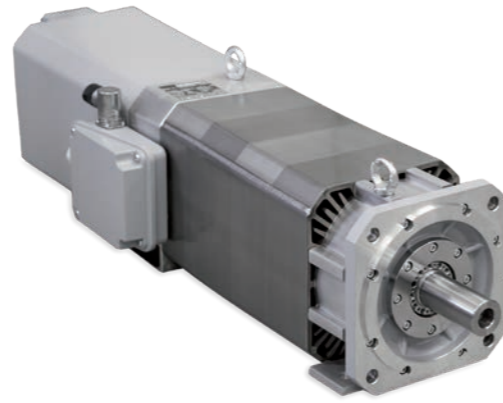

Motor	QAN 200UH	
Rated voltage U_N	330 V	
Rated power output P_N	10 kW	
Rated speed n_N	1500 rpm	
Rated torque M_N (105 K)	63.7 Nm	
Rated current I_N (105 K)	25 A	
Efficiency	0.85	
Maximum speed $n_{max}^{1)}$		
Spindle bearing	12 000 rpm	15 000 rpm
Max. current I_{max}	44 A	
Hollow shaft bore	\varnothing 9 mm	
Mass m	91 kg	
Rotor inertia J	405 kg·cm ²	
Protection	IP54	
Fan		
Rated voltage U_L	3AC 400 V	
Rated current I_L	0.17 A/0.2 A	
Frequency f_L	50 Hz/60 Hz	
ID		
Motor with spindle bearing	536257-18	536257-58

¹⁾The maximum shaft speed depends on the application conditions of the motor, such as the shaft load (see the *Motors Technical Manual*)

Rotatable connections

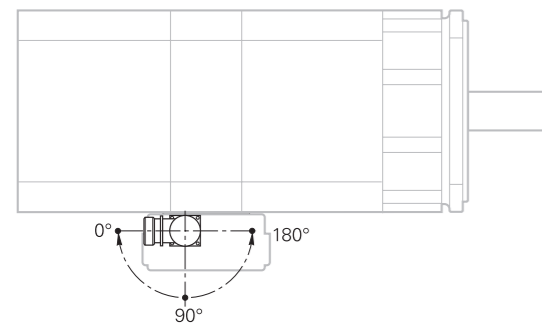

Encoder connector

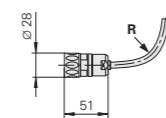

QAN 200UH 12 000 rpm

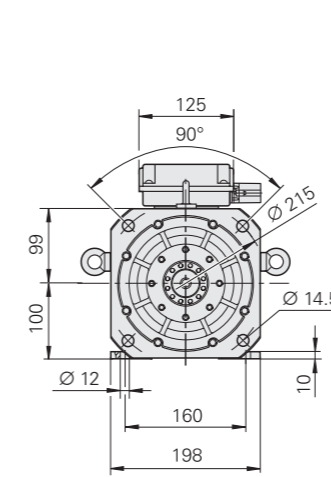

With spindle bearing

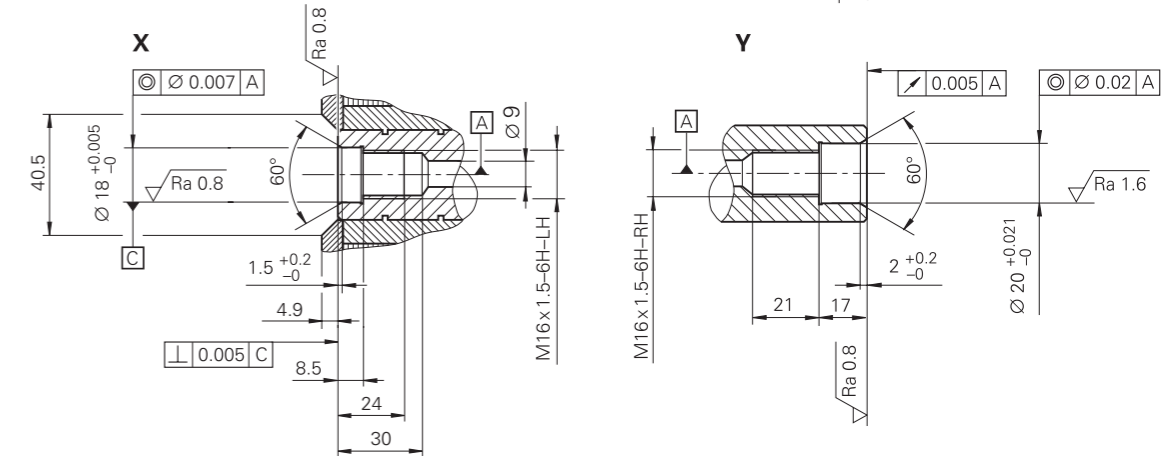
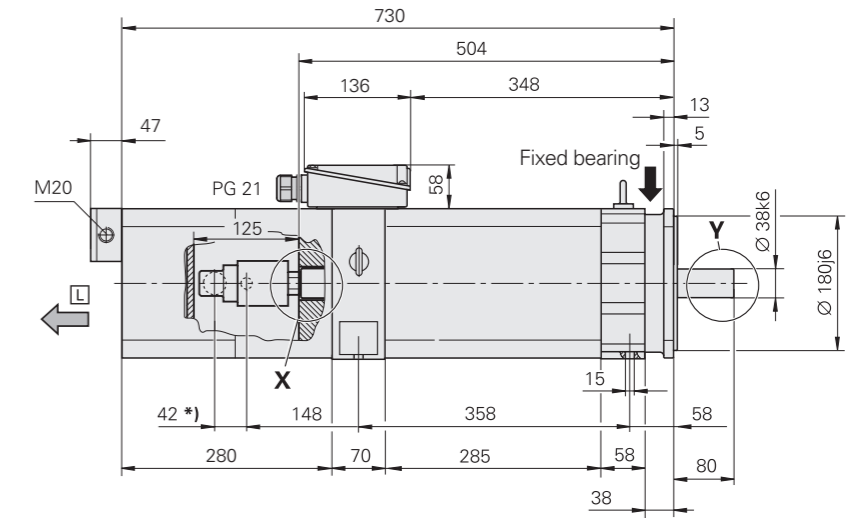

QAN 200UH 15 000 rpm

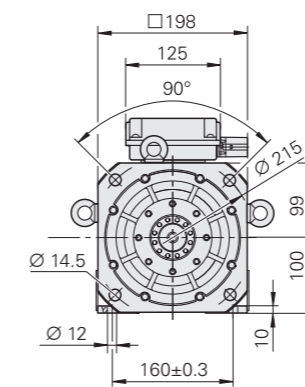

With spindle bearing

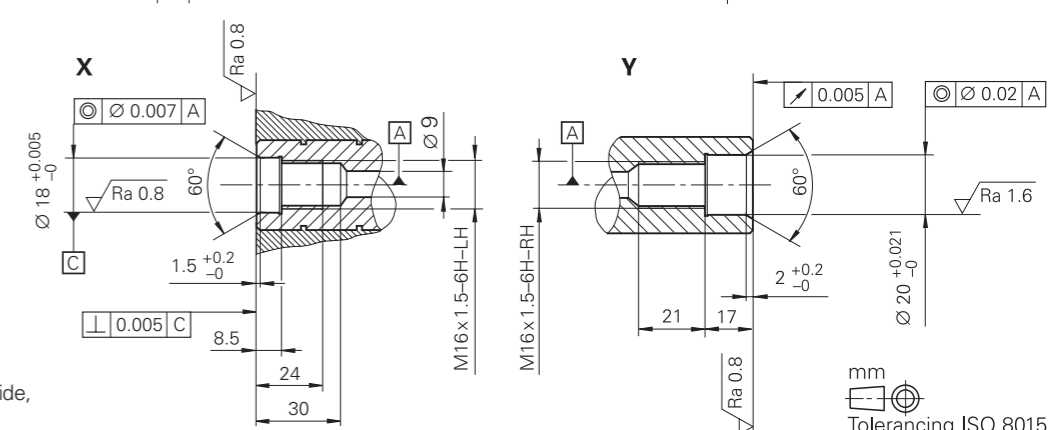
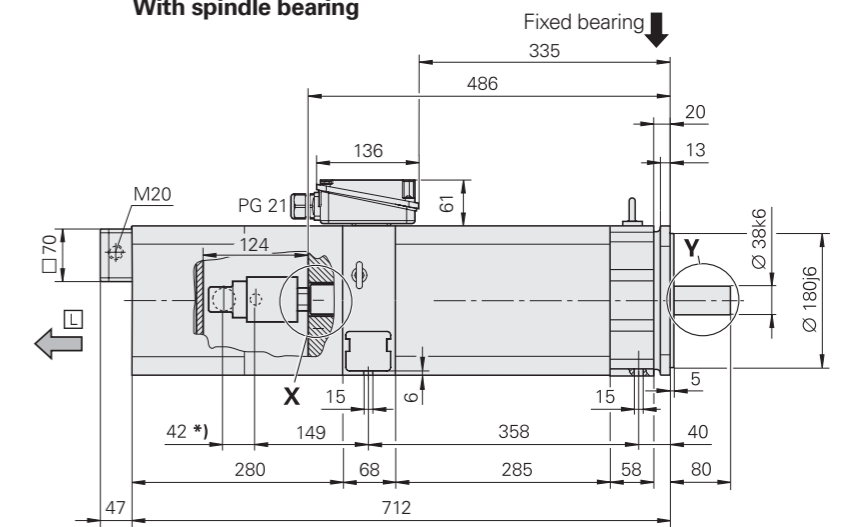

□ = Air flow
 PG 21: 13 mm to 18 mm
 M20: 6 mm to 12 mm

*) = Coolant connection on the right side, e.g., from Deublin 1109-020-188

mm
 Tolerancing ISO 8015
 ISO 2768:1989-mH
 ≤ 6 mm: ±0.2 mm

Asynchronous motors with hollow shaft

QAN 260xH series

Hollow-shaft spindle motor with two pole pairs

- Rated power output: 15 kW to 22 kW
- With spindle bearing



Motor	QAN 260MH	QAN 260LH	QAN 260UH
Rated voltage U_N	348 V	331 V	318 V
Rated power output P_N	15 kW	20 kW	22 kW
Rated speed n_N	1500 rpm		
Rated torque M_N (105 K)	96 Nm	128 Nm	140 Nm
Rated current I_N (105 K)	35 A	46 A	54 A
Efficiency	0.85		
Maximum speed n_{max}¹⁾ Spindle bearing*	12 000 rpm		10 000 rpm or 12 000 rpm
Max. current I_{max}	70 A	96 A	116 A
Mass m	120 kg	143 kg	158 kg
Rotor inertia J	700 kg·cm ²	920 kg·cm ²	1100 kg·cm ²
Protection	IP54		
Fan Rated voltage U_L Rated current I_L Frequency f_L	3AC 400 V 0.22 A/0.26 A 50 Hz/60 Hz		
ID Motor with spindle bearing			
10 000 rpm	–	–	536259-53
12 000 rpm	642855-73	631449-73	536259-73

¹⁾ The maximum shaft speed depends on the application conditions of the motor, such as the shaft load (see the *Motors Technical Manual*)

* Please select when ordering

Rotatable connections

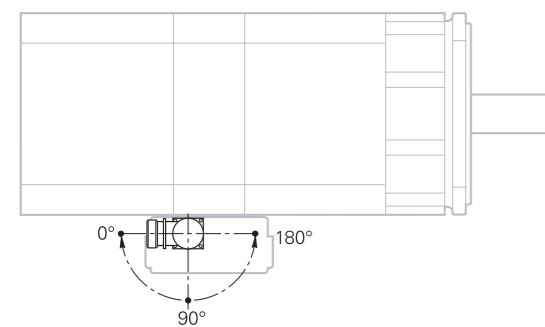

Encoder connector

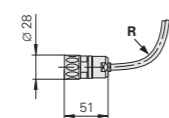

For **R** see page 56

QAN 260MH

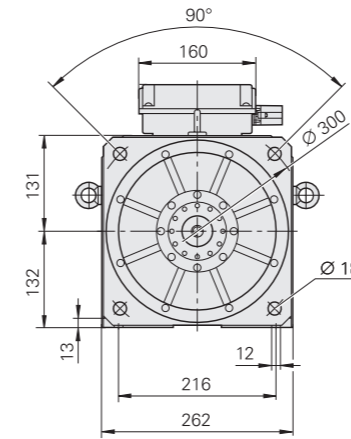

With spindle bearing

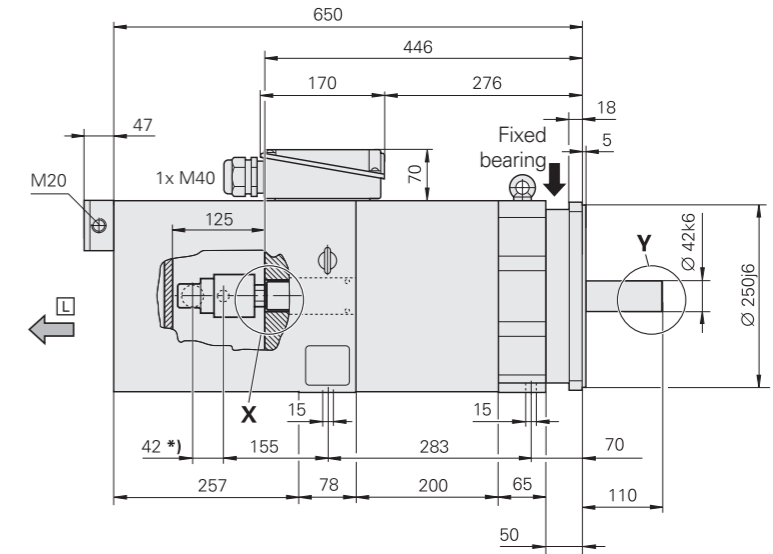

QAN 260LH

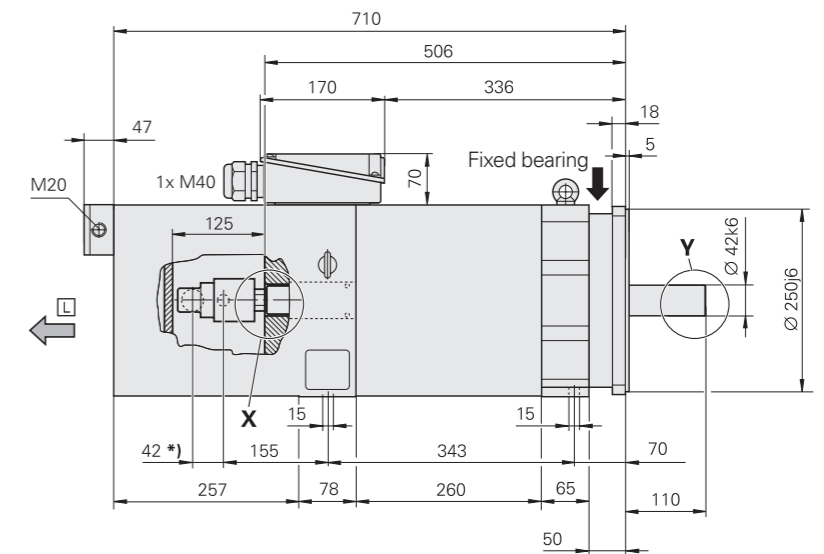
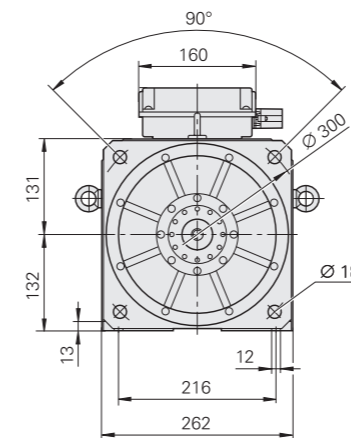

QAN 260UH

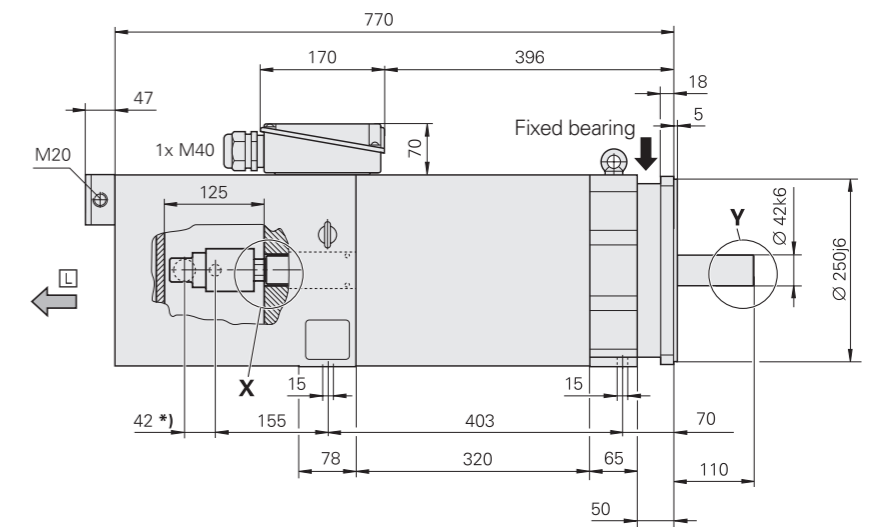
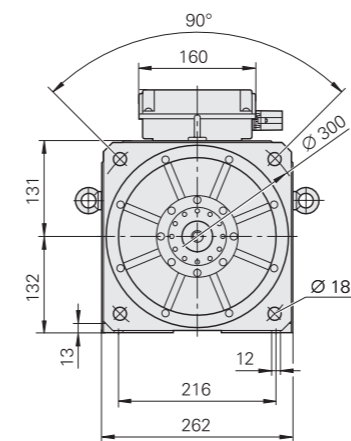

☐ = Air flow

QAN 260 MH

M20: 6 mm to 12 mm
M40: 20 mm to 26 mm

QAN 260 LH/UH

M20: 6 mm to 12 mm
M40: 22 mm to 32 mm

*) = Coolant connection on the right side, e.g., from Deublin 1109-020-188

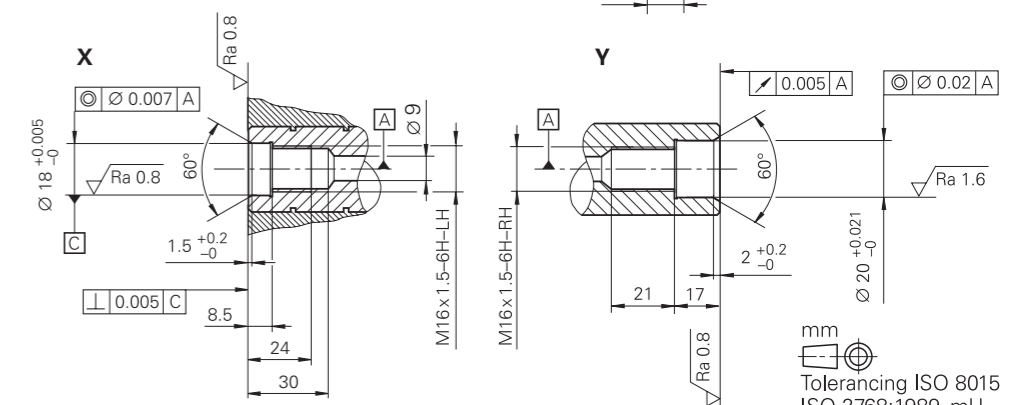

Asynchronous hollow-shaft motors

QAN 360UHW series

Hollow-shaft spindle motor with four pole pairs

- With spindle bearing
- Water-cooled



Motor	QAN 360UHW	
	Wye connection	Delta connection
Rated voltage U_N	420 V	320 V
Rated power output P_N	43.2 kW	
Rated shaft speed n_N	450 rpm	780 rpm
Rated torque M_N (105 K)	917 Nm	529 Nm
Rated current I_N (105 K)	113 A	124 A
Efficiency	0.82	0.89
Maximum speed n_{max} ¹⁾ Spindle bearing	7000 rpm	
Max. current I_{max}	190 A	
Mass m	483 kg	
Rotor inertia J	5990 kg·cm ²	
Protection	IP43	
Mounting direction	Horizontal: IM B5 Vertical: IM V1	
ID with key	641936-26 641936-06	

¹⁾The maximum shaft speed depends on the application conditions of the motor, such as the shaft load (see the *Motors Technical Manual*)

Rotatable connections

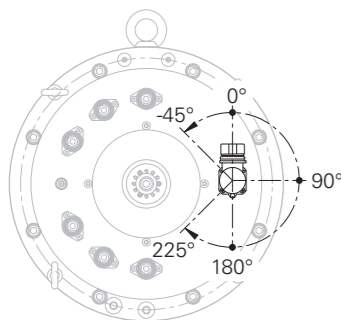

QAN 360UHW

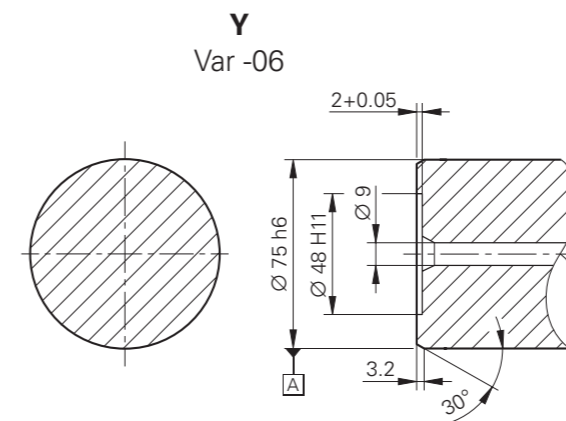
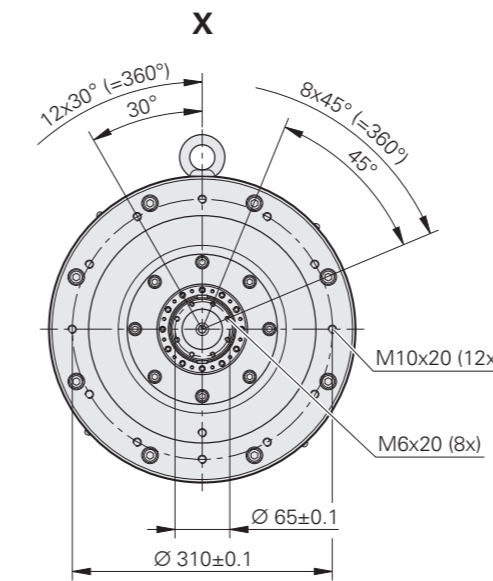
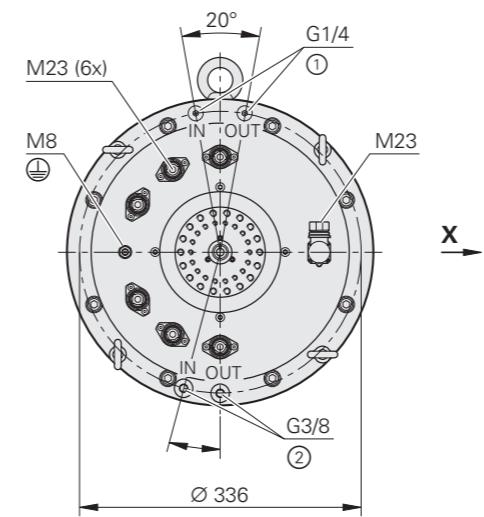

With spindle bearing

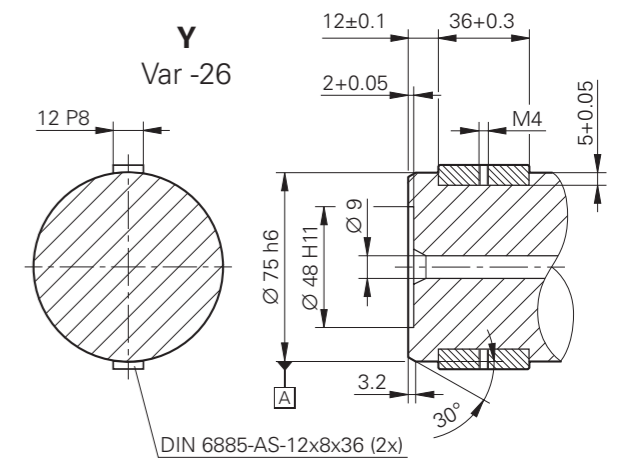
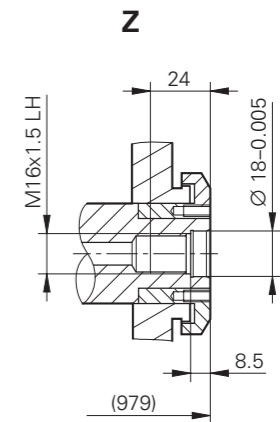
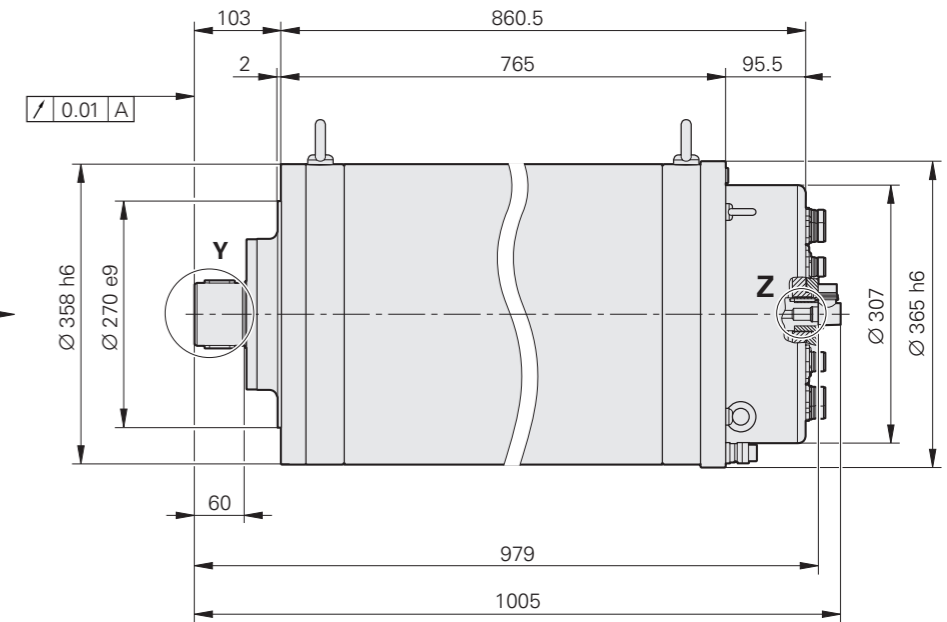

mm
Tolerancing ISO 8015
ISO 2768:1989-mH
≤ 6 mm: ±0.2 mm

1 = Connection for sealing air
2 = Connection for coolant

Asynchronous motors

Power and torque characteristics

QAN 200M

Duty cycle	Speed n	Power P	Torque M	Current I
S1	1 500 rpm	5.5 kW	35.0 Nm	18.0 A
	6 000 rpm	5.5 kW	8.8 Nm	–
	12 000 rpm	5.5 kW	4.4 Nm	–
S6-60%	1 500 rpm	7.0 kW	44.7 Nm	22.0 A
	6 000 rpm	7.0 kW	11.2 Nm	–
	12 000 rpm	7.0 kW	5.6 Nm	–
S6-40%	1 500 rpm	7.9 kW	50.4 Nm	24.0 A
	6 000 rpm	7.9 kW	12.6 Nm	–
	12 000 rpm	7.9 kW	6.3 Nm	–
S6-25%	1 500 rpm	9.5 kW	60.7 Nm	28.0 A
	6 000 rpm	9.5 kW	15.2 Nm	–
	12 000 rpm	9.5 kW	7.6 Nm	–

Power characteristic curve

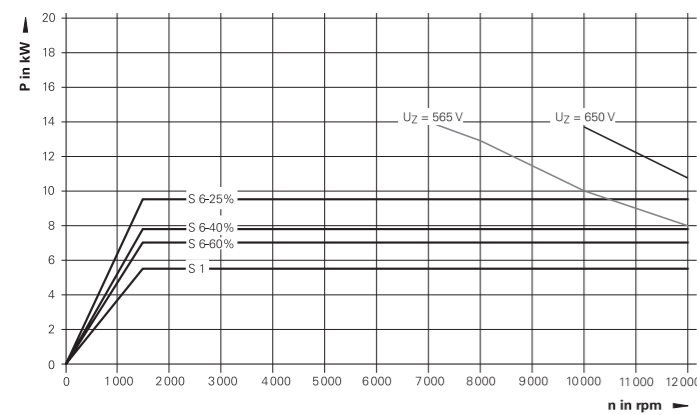

Torque characteristic curve

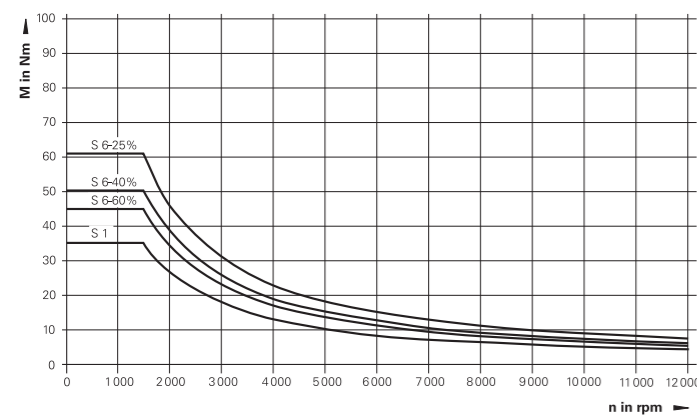

QAN 200L

Duty cycle	Speed n	Power P	Torque M	Current I
S1	1 500 rpm	7.5 kW	47.8 Nm	20.1 A
	6 000 rpm	7.5 kW	12.0 Nm	–
	12 000 rpm	7.5 kW	6.0 Nm	–
S6-60%	1 500 rpm	9.8 kW	62.6 Nm	24.0 A
	10 700 rpm	9.8 kW	9.5 Nm	–
	12 000 rpm	8.5 kW	6.8 Nm	–
S6-40%	1 500 rpm	11.5 kW	73.4 Nm	27.0 A
	9 000 rpm	11.5 kW	11.0 Nm	–
	12 000 rpm	8.5 kW	6.8 Nm	–
S6-25%	1 500 rpm	13.0 kW	83.0 Nm	31.0 A
	7 500 rpm	13.0 kW	16.6 Nm	–
	12 000 rpm	8.5 kW	6.8 Nm	–

Power characteristic curve

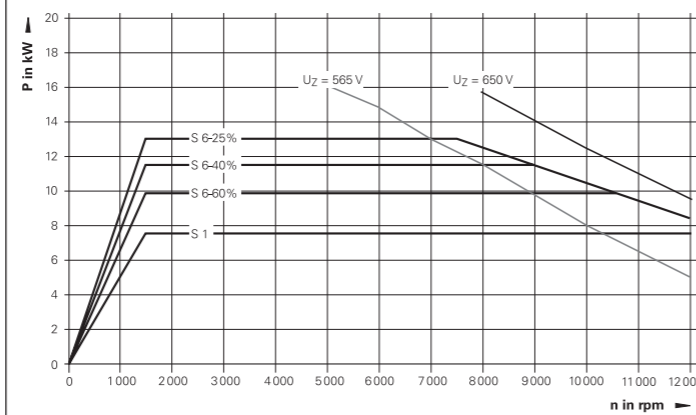

Torque characteristic curve

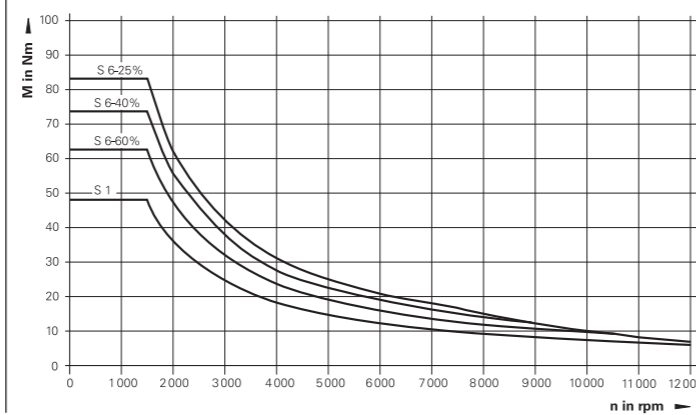

QAN 200U

Duty cycle	Speed n	Power P	Torque M	Current I
S1	1 500 rpm	10.0 kW	63.7 Nm	25.0 A
	10 000 rpm	10.0 kW	9.5 Nm	–
	12 000 rpm	8.0 kW	6.4 Nm	–
S6-60%	1 500 rpm	12.5 kW	79.8 Nm	29.0 A
	10 000 rpm	12.5 kW	11.9 Nm	–
	12 000 rpm	10.0 kW	8.0 Nm	–
S6-40%	1 500 rpm	14.0 kW	89.4 Nm	32.0 A
	9 000 rpm	14.0 kW	14.6 Nm	–
	12 000 rpm	11.0 kW	8.8 Nm	–
S6-25%	1 500 rpm	17.0 kW	108.6 Nm	37.0 A
	7 500 rpm	17.0 kW	21.7 Nm	–
	12 000 rpm	12.0 kW	9.5 Nm	–

Power characteristic curve

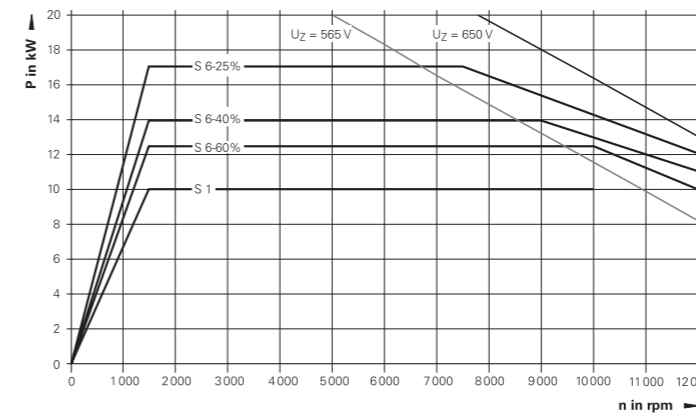

Torque characteristic curve

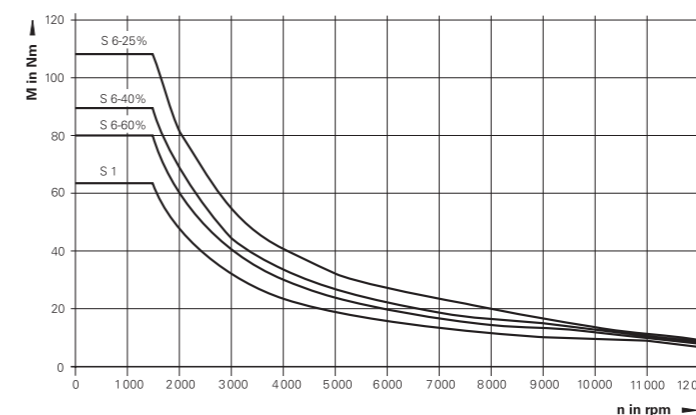

QAN 200UH

Duty cycle	Speed n	Power P	Torque M	Current I
S1	1 500 rpm	10.0 kW	63.7 Nm	25.0 A
	10 000 rpm	10.0 kW	9.5 Nm	–
	12 000 rpm	8.0 kW	6.4 Nm	–
	15 000 rpm	4.0 kW	2.5 Nm	–
S6-60%	1 500 rpm	12.5 kW	79.8 Nm	29.0 A
	10 000 rpm	12.5 kW	11.9 Nm	–
	12 000 rpm	10.0 kW	8.0 Nm	–
	15 000 rpm	5.0 kW	3.2 Nm	–
S6-40%	1 500 rpm	14.0 kW	89.4 Nm	32.0 A
	9 000 rpm	14.0 kW	19.1 Nm	–
	12 000 rpm	11.0 kW	8.8 Nm	–
	15 000 rpm	6.0 kW	3.8 Nm	–
S6-25%	1 500 rpm	17.0 kW	108.6 Nm	37.0 A
	7 500 rpm	17.0 kW	21.7 Nm	–
	12 000 rpm	12.0 kW	9.5 Nm	–
	15 000 rpm	7.0 kW	4.5 Nm	–

Power characteristic curve

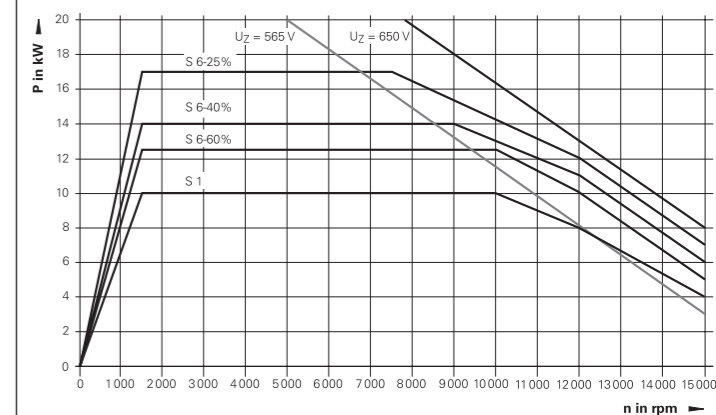

Torque characteristic curve

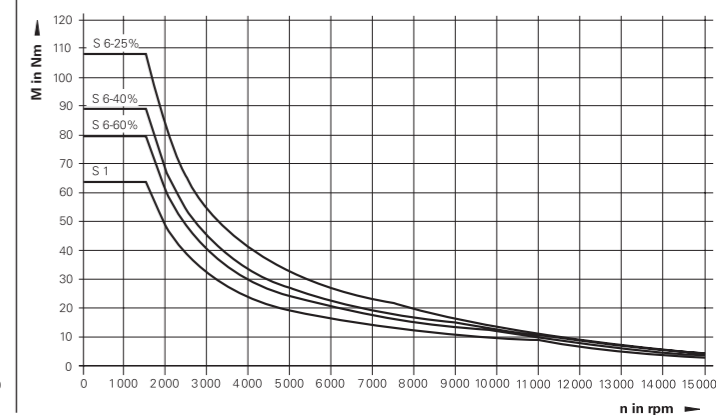

Note
 • **S6 mode**
 Cycle duration: 10 minutes
 During the rest period the motor is idle.

QAN 260M, QAN 260MH

Duty cycle	Speed n	Power P	Torque M	Current I
S1	1 500 rpm	15.0 kW	95.5 Nm	35.0 A
	6 500 rpm	15.0 kW	22.0 Nm	–
	10 000 rpm	10.0 kW	9.5 Nm	–
	12 000 rpm	4.0 kW	3.2 Nm	–
S6-60%	1 500 rpm	20.0 kW	127.3 Nm	43.3 A
	5 000 rpm	20.0 kW	38.2 Nm	–
	9 000 rpm	13.5 kW	14.3 Nm	–
S6-40%	1 500 rpm	25.0 kW	159.2 Nm	52.3 A
	4 500 rpm	25.0 kW	53.1 Nm	–
	8 000 rpm	16.8 kW	20.1 Nm	–
S6-25%	1 500 rpm	32.0 kW	203.7 Nm	65.0 A
	4 000 rpm	32.0 kW	76.4 Nm	–
	6 000 rpm	23.7 kW	37.7 Nm	–

Power characteristic curve

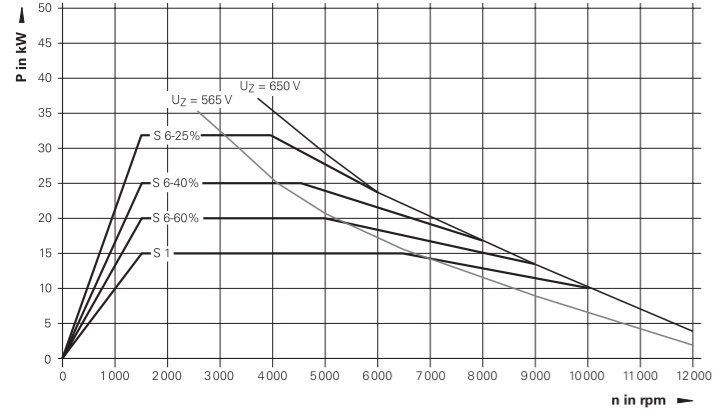

Torque characteristic curve

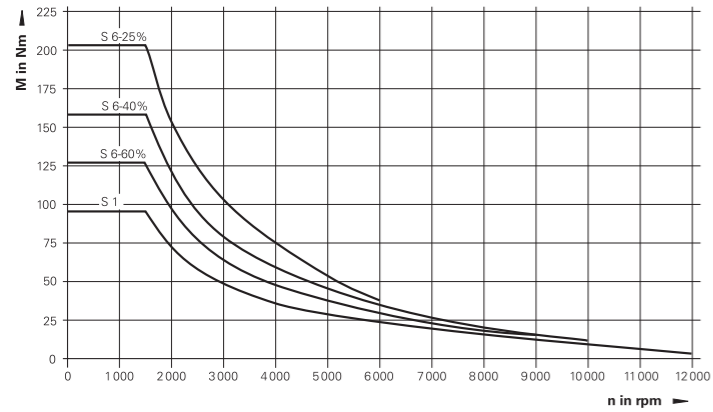

QAN 260L, QAN 260LH

Duty cycle	Speed n	Power P	Torque M	Current I
S1	1 500 rpm	20.0 kW	127.3 Nm	46.0 A
	6 500 rpm	20.0 kW	29.4 Nm	–
	10 000 rpm	13.0 kW	12.4 Nm	–
	12 000 rpm	8.0 kW	6.4 Nm	–
S6-60%	1 500 rpm	25.0 kW	159.2 Nm	56.0 A
	6 000 rpm	25.0 kW	39.4 Nm	–
	10 000 rpm	16.0 kW	15.3 Nm	–
	12 000 rpm	8.0 kW	6.4 Nm	–
S6-40%	1 500 rpm	30.0 kW	191.0 Nm	65.0 A
	5 500 rpm	30.0 kW	52.1 Nm	–
	10 000 rpm	17.5 kW	16.7 Nm	–
S6-25%	1 500 rpm	37.0 kW	235.5 Nm	79.0 A
	5 000 rpm	37.0 kW	70.7 Nm	–
	8 000 rpm	24.0 kW	28.6 Nm	–

Power characteristic curve

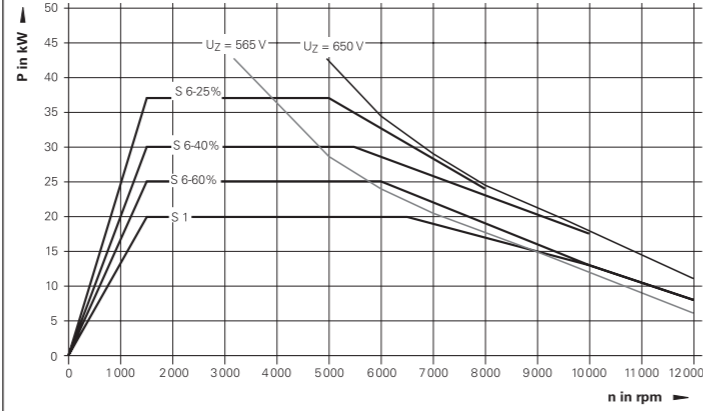

Torque characteristic curve

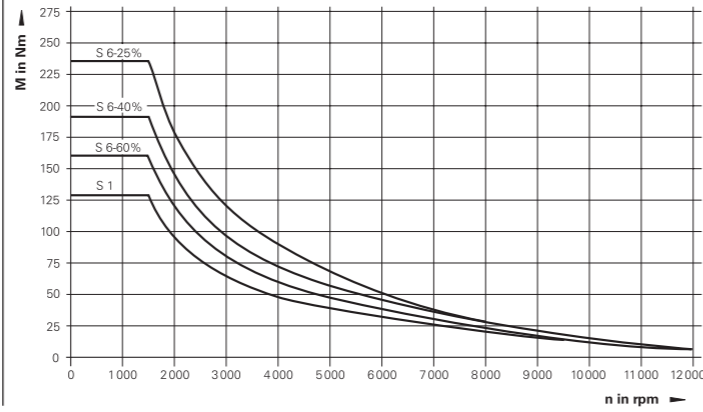

QAN 260U

Duty cycle	Speed n	Power P	Torque M	Current I
S1	1 500 rpm	24.0 kW	152.8 Nm	58.0 A
	7 400 rpm	24.0 kW	31.0 Nm	–
	10 000 rpm	18.0 kW	17.2 Nm	–
S6-60%	1 500 rpm	30.0 kW	191.0 Nm	67.2 A
	7 000 rpm	30.0 kW	40.9 Nm	–
	10 000 rpm	22.5 kW	21.5 Nm	–
S6-40%	1 500 rpm	38.0 kW	241.9 Nm	81.8 A
	5 500 rpm	38.0 kW	66.0 Nm	–
	10 000 rpm	26.0 kW	24.8 Nm	–
S6-25%	1 500 rpm	48.0 kW	305.6 Nm	100.6 A
	4 500 rpm	48.0 kW	101.9 Nm	–
	7 000 rpm	41.0 kW	55.9 Nm	–

Power characteristic curve

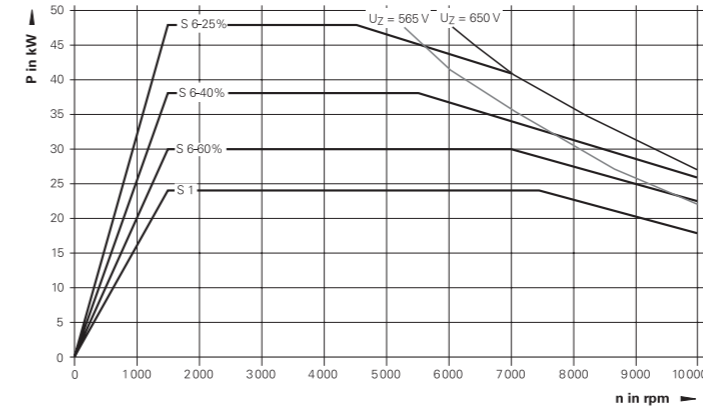

Torque characteristic curve

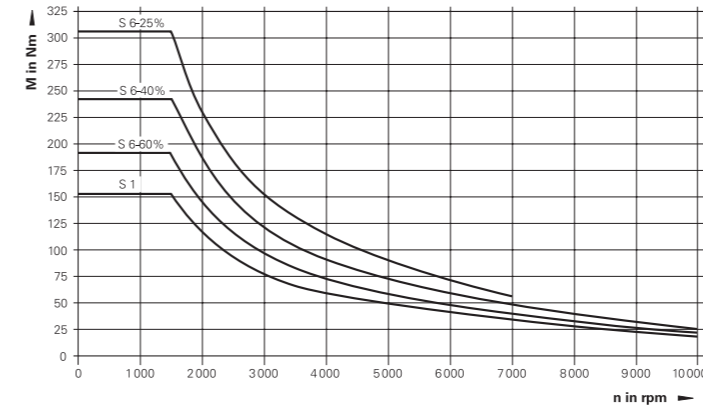

QAN 260UH

Duty cycle	Speed n	Power P	Torque M	Current I
S1	1 500 rpm	22.0 kW	140.1 Nm	54.0 A
	7 400 rpm	22.0 kW	28.4 Nm	–
	10 000 rpm	16.0 kW	15.3 Nm	–
S6-60%	1 500 rpm	30.0 kW	191.0 Nm	67.0 A
	6 500 rpm	30.0 kW	44.1 Nm	–
	10 000 rpm	20.0 kW	19.5 Nm	–
S6-40%	1 500 rpm	35.0 kW	222.8 Nm	77.0 A
	6 500 rpm	35.0 kW	66.8 Nm	–
	10 000 rpm	24.0 kW	22.9 Nm	–
S6-25%	1 500 rpm	46.0 kW	286.5 Nm	97.0 A
	5 000 rpm	46.0 kW	85.9 Nm	–
	10 000 rpm	27.0 kW	25.8 Nm	–

Power characteristic curve

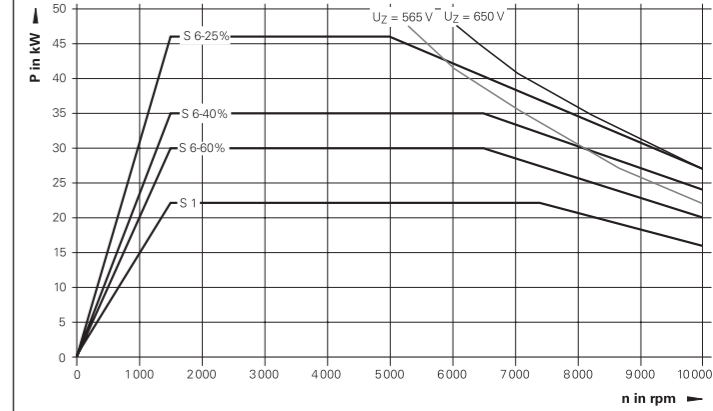

Torque characteristic curve

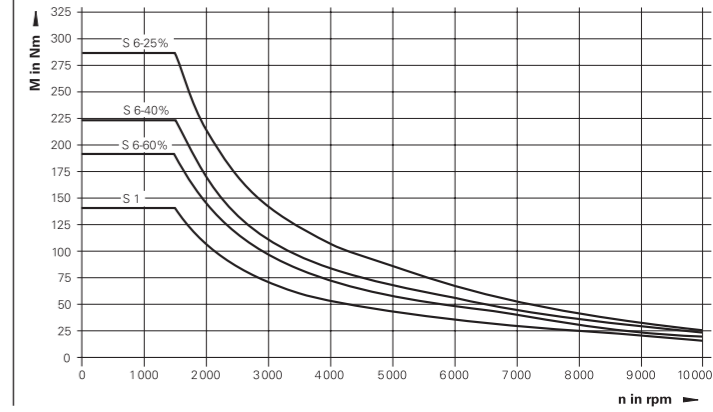

QAN 320M

Duty cycle	Speed n	Power P	Torque M	Current I
S1	1 500 rpm	32.0 kW	203.7 Nm	77.5 A
	5 500 rpm	32.0 kW	55.0 Nm	–
	10 000 rpm	19.5 kW	18.6 Nm	–
S6-60%	1 500 rpm	43.0 kW	273.7 Nm	98.0 A
	5 500 rpm	43.0 kW	71.5 Nm	–
	10 000 rpm	25.0 kW	23.9 Nm	–
S6-40%	1 500 rpm	53.0 kW	337.4 Nm	118.0 A
	5 500 rpm	53.0 kW	86.2 Nm	–
	6 000 rpm	48.0 kW	76.4 Nm	–

Power characteristic curve

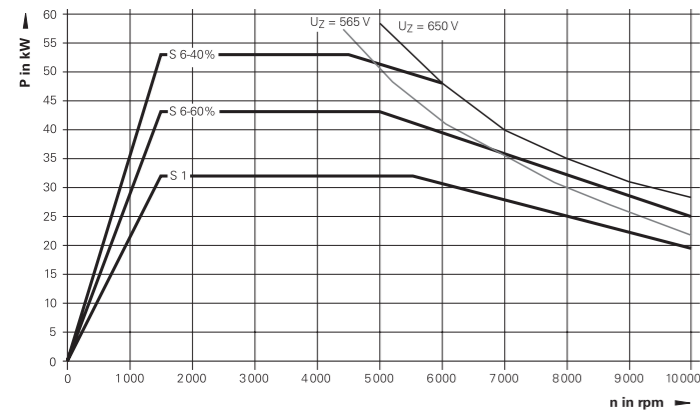

Torque characteristic curve

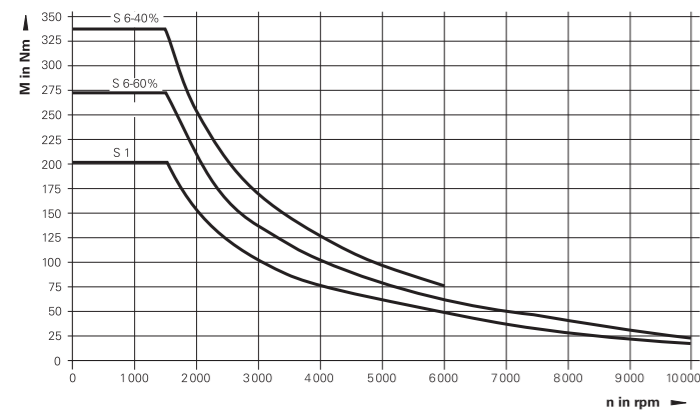

QAN 320L

Duty cycle	Speed n	Power P	Torque M	Current I
S1	1 500 rpm	40.0 kW	254.6 Nm	99.0 A
	5 000 rpm	40.0 kW	77.9 Nm	–
	10 000 rpm	21.0 kW	21.0 Nm	–
S6-60%	1 500 rpm	53.0 kW	337.4 Nm	123.0 A
	4 500 rpm	53.0 kW	112.5 Nm	–
	10 000 rpm	24.0 kW	22.9 Nm	–
S6-40%	1 500 rpm	66.0 kW	420.2 Nm	148.0 A
	4 500 rpm	66.0 kW	140.1 Nm	–
	10 000 rpm	28.0 kW	26.7 Nm	–

Power characteristic curve

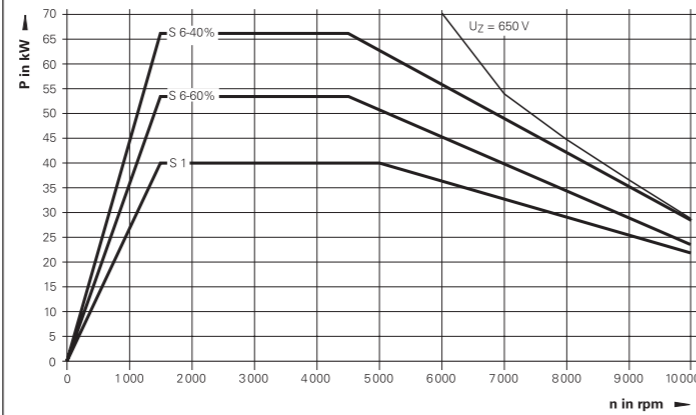

Torque characteristic curve

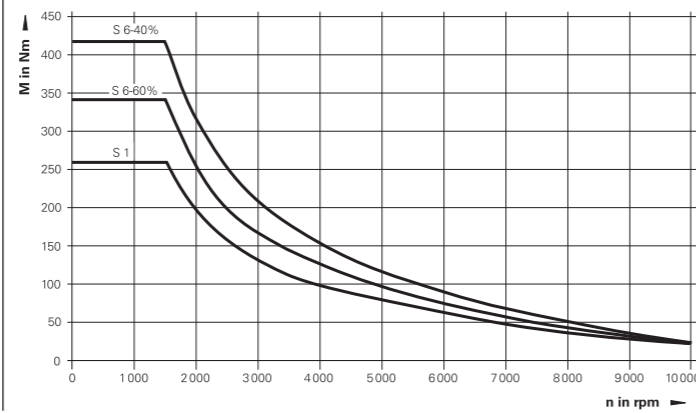

QAN 360UHW

Wye connection

Duty cycle	Speed n	Power P	Torque M	Current I
S1	450 rpm	43.2 kW	917 Nm	113 A
	800 rpm	43.2 kW	515 Nm	–
S6-40%	450 rpm	60 kW	1290 Nm	–
	600 rpm	60 kW	955 Nm	–

Power characteristic curve

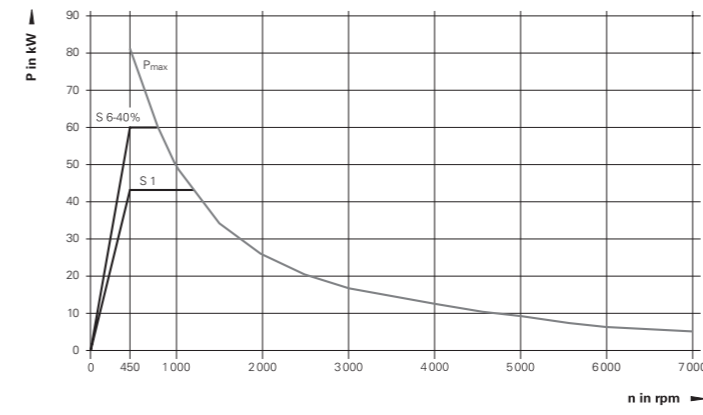

Torque characteristic curve

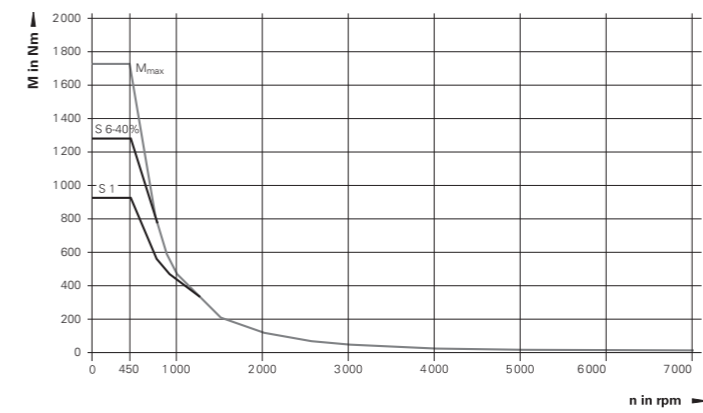

QAN 360UHW

Delta connection

Duty cycle	Speed n	Power P	Torque M	Current I
S1	780 rpm	43.2 kW	529 Nm	124 A
	3 500 rpm	43.2 kW	110 Nm	–
S6-40%	780 rpm	60 kW	720 Nm	–
	2 500 rpm	60 kW	220 Nm	–

Power characteristic curve

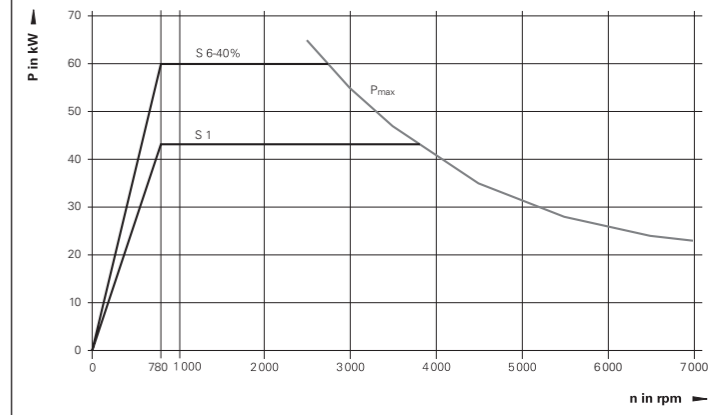

Torque characteristic curve

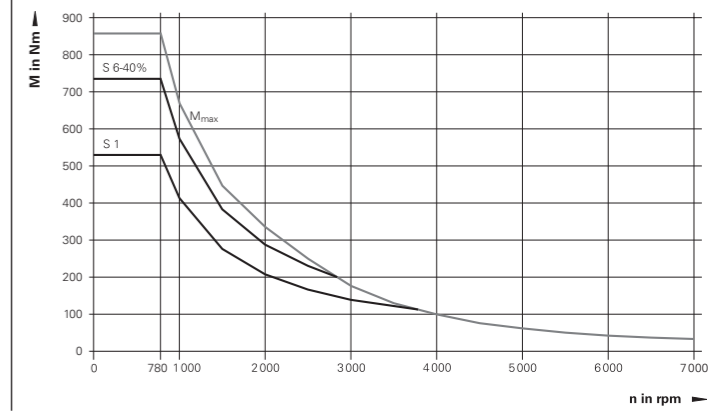

Asynchronous motors

Cables

Power cables

Current load at ambient temperature of up to 40 °C

	Cable without connectors	Bend radius R for frequent flexing	Cable type	Diameter
Current load of up to 26 A (installation type B2)				
QAN 200M QAN 200L QAN 200U QAN 200UH	ID 818787-xx <i>ID 1213900-xx</i>	≥ 69 mm ≥ 109 mm	PUR [4 x 4 mm ²]	13.8 mm <i>14.5 mm</i>
Current load of up to 45.2 A (installation type B2)				
QAN 260M QAN 260MH	ID 818782-xx <i>ID 1213901-xx</i>	≥ 102 mm ≥ 157 mm	PUR [4 x 10 mm ²]	20.3 mm <i>20.9 mm</i>
Current load of up to 59.9 A (installation type B2)				
QAN 260L QAN 260LH QAN 260U QAN 260UH	ID 818510-xx <i>ID 1213902-xx</i>	≥ 133 mm ≥ 207 mm	PUR [4 x 16 mm ²]	26.5 mm <i>27.5 mm</i>
Current load of up to 93.8 A (installation type B2)				
QAN 320M	ID 818781-xx <i>ID 1213903-xx</i>	≥ 173 mm ≥ 258 mm	PUR [4 x 35 mm ²]	34.5 mm <i>34.3 mm</i>
Current load of up to 117.5 A (installation types C and E)				
QAN 320L	ID 818781-xx <i>ID 1213903-xx</i>	≥ 173 mm ≥ 258 mm	PUR [4 x 35 mm ²]	34.5 mm <i>34.3 mm</i>
Current load of up to 125.7 A (installation types C and E)				
Cable from inverter to switch box	ID 1213903-xx	≥ 258 mm	PUR [4 x 35 mm ²]	34.3 mm
Current load of up to 124.5 A (installation types C and E)				
QAN 360UHW¹⁾	Recommended power cable: cable without connecting elements, 6 individual wires and each 35 mm ² (unshielded) from the motor to the switch box			

Italics: shielded power cable

¹⁾ Connector set required (not included in delivery). For more information, see *M23 connector set* under *Accessories*.



Further information:

For detailed information about the electrical connection of the QAN 360 UHW, see the *Motors* Technical Manual.

Encoder cables

	Cable length	Cable complete with connectors	Line drop compensator	Extension cable	Bend radius R for frequent flexing
All QANs	< 30 m	ID 289440-xx	–	ID 336847-xx (as needed)	≥ 100 mm
	> 30 m	ID 289440-xx	ID 370226-01	ID 336847-xx	

Cables for fans

	Cable without connectors	Bend radius R for frequent flexing	Cable type	Diameter
All QANs	ID 818789-xx <i>ID 1213898-xx</i>	≥ 50 mm ≥ 82 mm	PUR [4 x 0.75 mm ²]	9.9 mm <i>10.9 mm</i>

Italics: shielded power cable

Accessories

Toroidal cores

Large line lengths can result in voltage peaks that may damage the motor. For cables longer than 15 m between the motor and the inverter, additional interference suppression measures may be necessary for 1xx inverter systems. One toroidal core is required per phase. The toroidal cores must be located in close proximity to the inverter (max. 2 m).

Toroidal core

For motor line > 15 m
ID 827054-01

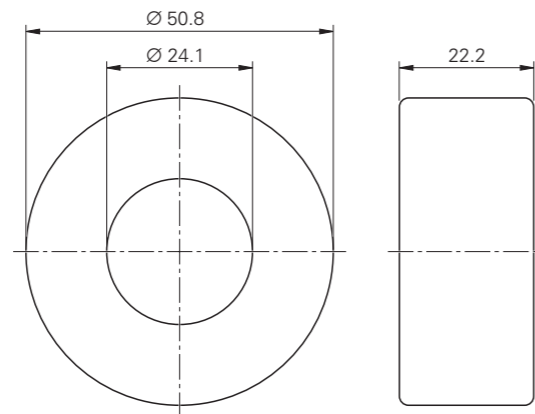
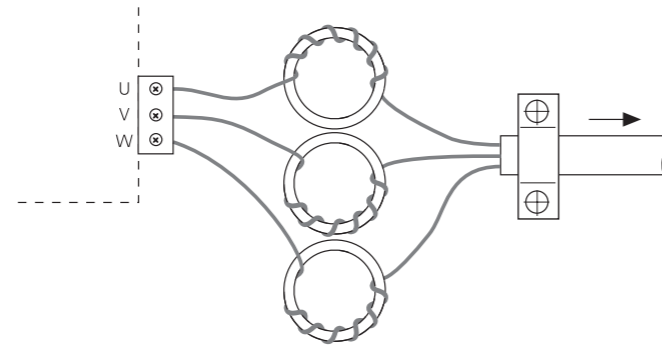

M23 connector set

For crimping the 1-pin M23 connector for the motor connection, the connector set contains the following components:

- Six connectors
- Six female contacts
- Mounting Instructions

ID 1288941-01

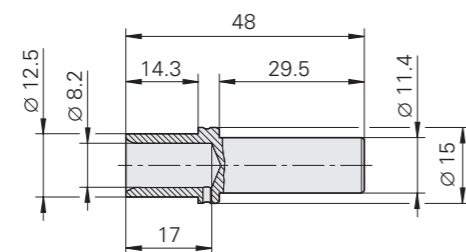

Female contact

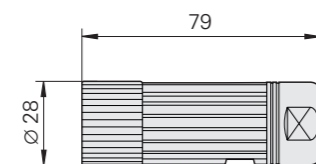

Connector

mm
Tolerancing ISO 8015
ISO 2768:1989-mH
≤ 6 mm: ±0.2 mm

Direct-drive torque motors

Besides synchronous and asynchronous motors, HEIDENHAIN offers a comprehensive assortment of standard torque motors. With more than 100 models, almost any requirement can be met.

Overview of the most important features:

- Outside diameter of up to 1290 mm
- Large hollow shaft of up to 1070 mm
- Maximum rated speed of up to 5170 rpm
- Peak torque of up to 31 200 Nm
- Very high continuous torque
- Field-weakening compliant
- With or without cage with coolant ducts
- Conceived for highly demanding applications

Direct coupling of the load with the rotor eliminates the need for any mechanical transfer elements such as transmissions, toothed belts or worm gears. The maintenance-free direct-drive motors therefore offer excellent dynamic performance while guaranteeing a long service life.

The torque motors offer the advantage of a patented, cogging-free design. This design provides outstanding peak power density in the magnet gap as well as unique thermal efficiency, thereby constituting a significant advantage with respect to precision that reacts negatively to thermal drift.

Further advantages of torque motors are:

- Patented and proven technology
- Excellent performance
- High quality
- Easy integration
- Wide product range

The torque motors are developed and produced by ETEL, a company of the HEIDENHAIN Corporate Group.

Further information:

For more information about the torque motors from ETEL, visit www.etel.ch



Direct-drive torque motors

HEIDENHAIN

Mastering nanometer accuracy



HEIDENHAIN

DR. JOHANNES HEIDENHAIN GmbH
Dr.-Johannes-Heidenhain-Straße 5
83301 Traunreut, Germany
☎ +49 8669 31-0
☎ +49 8669 32-5061
info@heidenhain.de

www.heidenhain.com

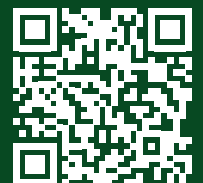

HEIDENHAIN
worldwide